



DELAWARE ELECTRIC CO-OP

"We Keep the Lights On"

**TECHNICAL REQUIREMENTS FOR PARALLEL
OPERATION OF CUSTOMER-OWNED GENERATION**

Effective September 7, 2018

(Revised January 4, 2022)

**TECHNICAL CONSIDERATIONS COVERING PARALLEL
OPERATIONS OF CUSTOMER-OWNED GENERATION
INTERCONNECTED WITH THE DELAWARE ELECTRIC CO-OP**

Table of Contents

<u>Topic</u>	<u>Page No.</u>
I. Disclaimer	1
II. Prerequisites & Interconnection Process	1
III. Interconnection Studies and Screening Criteria	2
IV. Interconnection Standards	3
V. Interconnection Request Processing Fees.....	26
VI. Applicability	27
VII. Definitions	29
VIII. Introduction and Purpose	32
IX. Generator Owner Obligations.....	32
X. DEC Power Delivery Obligations.....	35
XI. Technical Design Considerations	36
XII. Performance Considerations.....	49
XIII. Protection Scheme Details	52
XIV. Typical One-Line Diagrams	56
XV. Interconnection Application for Non-PJM Generation	57
XVI. References.....	58

Appendices

Appendix A	Generator Protection Guidelines for Units (50 MW & Above)
Appendix B	Information to Be Supplied By Generator Owner for Non PJM Projects (500 kW and Above)
Appendix C	Delaware Electric Co-op Generator Interconnection Applications (100 kW, or Less)
Appendix D	Delaware Electric Co-op Generator Interconnection Applications (100 kW to 500 kW AC)
Appendix E	Delaware Electric Co-op Generator Interconnection Applications (500 kW AC and Greater)
Appendix F	Typical Basic One-Line Diagrams

TECHNICAL CONSIDERATIONS COVERING PARALLEL OPERATIONS OF CUSTOMER-OWNED GENERATION INTERCONNECTED WITH THE DELAWARE ELECTRIC CO-OP

I. Disclaimer

This document and all the material contained herein is designed for informational and illustrative purposes and to insure at least minimum interconnection requirements are satisfied. It is produced as an aid to those Customers contemplating the purchase of generation equipment and interconnecting this generation equipment with the Delaware Electric Co-op. The information is intended to guide the customer in making a decision on whether to proceed with a more detailed engineering study.

All the information in this document is intended to be typical and of a general nature for information purposes. It is not intended to be site or Facility specific. Requirements and practices are also subject to change and it must be recognized that any given item may become obsolete or be modified in the future.

The requirements in this document are the requirements of Delaware Electric Co-op (DEC), and may also be requirements of the PJM Interconnection. For generation interconnections in the PJM queue, the PJM Tariff shall prevail in the event of any contradiction between the requirements of this document and the PJM Tariff.

II. Prerequisite & Interconnection Process

To interconnect with the Delaware Electric Co-op (DEC) system, the Customer must first be in compliance with the Tariff rules and regulations and the applicable Tariff classifications and rates. The terms and conditions contained within this document are in addition to, but do not modify nor negate, the terms of the Tariff. In cases where the Customer will not be selling energy and/or capacity into PJM markets, a Generator Owner can submit an Interconnection Application and enter into an Interconnection Agreement Contract directly with DEC. This two-party Interconnection Agreement Contract will cover the interconnection and the use of DEC's facilities to enable the transfer of power from or to the Facility. The details of the Interconnection Agreement Contract are outside the scope of this document. However, this Technical Considerations Document may be included in and become part of the overall Interconnection Agreement Contract.

Alternatively, if the Customer intends to sell energy and or capacity into PJM markets, a Generator Owner must submit an Interconnection Request directly to PJM. PJM will initiate a process to study the feasibility of the generation, its impact within the PJM transmission system and the cost to make any necessary transmission system improvements. These transmission system improvements may be outside the service territory of the local utility. The extent of the studies is dependent on the size of the generation and the proposed Point of Interconnection. Again, the details of this process are outside the scope of this document. The Generator Owner must also enter into the appropriate agreement with PJM.

III. Interconnection Studies and Screening Criteria.

Effective January 12, 2021, DEC's new guidelines apply to interconnections of all types of distributed generation systems of less than 10 MW to the electric distribution system for the utility. DEC now utilizes a four-tiered approach to determine the level of review required before a system may be connected to the grid. Different levels of review are subject to specific technical screens, review procedures, and time lines. The review process becomes more extensive and time consuming with increasing system size. Below are the basic criteria for determining the level of review required for a prospective project.

Tier 1: Lab certified, inverter-based systems with a nameplate capacity of 10 kW or less.

Tier 2: Lab certified or field approved inverter-based systems with a nameplate capacity of 2 MW or less connected to a radial distribution circuit or to a spot network serving one customer. Alternatively, the system was reviewed and not approved under Tier 1.

Tier 3: Only applies to systems that will not export power to the grid and which do not require new facility construction by the utility. These systems must have an aggregate generation of 5% of an area network's maximum load or 50 kW, whichever is less. Systems located on a radial network must have a capacity of 10 MW or less and not be served by a shared transformer. These systems are also subject to additional criteria dealing with the aggregate capacity of interconnected systems on a given network.

Tier 4: Systems with a nameplate capacity of 10 MW or less that cannot be approved or do not meet the criteria for review under a lower tier.

An interconnection request may be eligible for expedited review if small generator facilities use lab certified equipment or field approved interconnection equipment. Lab certified equipment is defined to mean equipment tested and approved by a nationally recognized testing laboratory (NRTL) as being in accordance with applicable IEEE standards, UL certification, and the National Electric Code (NEC). Field approved systems are generally non-certified systems that have been tested and approved under a review by a utility over the last 36 months and are subject to certain other restrictions including utility witness tests.

Screening criteria to determine the level of review required for the aggregate exporting generating facilities.

- 1- Interconnection Studies will be required for any generating facility that exceeds the 50% capacity limit of the circuit or the station where is being connected.
- 2- All other generating facilities will be eligible for expedited review.

All interconnected systems must be equipped with a utility accessible “lockable, visible-

break isolation device” or alternately, a “draw-out type circuit breaker with a provision for padlocking at the draw-out position”. This requirement is equivalent to “lockable external disconnect switch” frequently specified in other jurisdictions.

Any systems that will be in excess of 500 kW must enter into a small generation interconnection agreement (SGIA).

IV. Interconnection Standards

A. Scope

This section applies to a small electricity generator facility seeking to interconnect to the electric distribution system which meets the following criteria:

1. The nameplate capacity of the small generator facility is equal to or less than 10 MW (for Rate X, 1 MW or less); and
2. The small generator facility is not subject to the interconnection requirements of PJM Interconnection, LLC; and
3. The small generator facility is designed to operate in parallel with the electric distribution system; and
4. The applicant will not operate the small generator facility until the Company’s application and inspection process is completed. **Unauthorized system interconnection and operation will result in no payment for excess generation credits and the danger of disconnection of service until the application is approved.**

B. Definitions

In this section, the following terms have the meanings indicated.

Terms Defined.

“Adverse system impact” means a negative effect, due to technical or operational limits on conductors or equipment being exceeded, that may compromise the safety or reliability of the electric distribution system.

“Affected system” means a DEC distribution system that is affected by the interconnection of a small generator to another distribution company’s distribution system without impacting a transmission system regulated by the Federal Energy Regulatory Commission.

“Aggregated Meters” refers to an individual member with multiple accounts at single or multiple premises where a single member can aggregate Net Metering generation credits to multiple accounts and/or premises under the provisions of DEC.

“Applicant” means a person who has submitted an interconnection request to interconnect a small generator facility to DEC’s electric distribution system.

“Application Approval” means the Company has received and acknowledged a completed application, and processed the request for interconnection based on the provisions contained in DEC Technical Requirements for Member-owned Generation. All applicable safety, local building codes and interconnection requirements have been met and the Company has issued final written authorization to begin energy generation connected to the Company’s distribution system.

“Area network” means a type of electric distribution system served by multiple transformers interconnected in an electrical network circuit, often used in large, densely populated metropolitan areas.

“Certificate of completion” means a certificate on a form approved by the Commission containing information about the interconnection equipment to be used, its installation and local inspections.

“Commissioning test” mean one of several tests applied to a small generator facility by the applicant after construction is completed to verify that the facility does not create adverse system impacts, including the test specified in section 5.4 of IEEE Standard 1547.

“Community Energy Facility” refers to a host member and one or more subscribers covering multiple premises where a Community Energy Facility, either behind the meter of a Subscriber or as a stand-alone facility, provides Net Metering for multiple Subscribers and multiple premises.

“Distribution upgrade” means a required addition or modification to DEC’s electric distribution system, excluding the interconnection facilities, necessary to accommodate the interconnection of a small generator facility.

“Draw-out type circuit breaker” means a molded case switching device that can be inserted into or removed from its enclosure during no-load conditions. This switching device is capable of making, carrying and breaking currents under normal and abnormal circuit conditions.

“Electric distribution system” means the facilities and equipment used to transmit electricity generally at less than 69 kV to ultimate usage points such as homes and industries from interchanges with higher voltage transmission networks that transport bulk power over longer distances, and same meaning as the term Area EPS as defined in section 3.1.6.1 of IEEE Standard 1547.

“Fault current” means the electrical current that flows through a circuit during an electrical fault condition, such as when one or more electrical conductors contact ground or each other.

“IEEE Standard 1547 and 1547.1” means the international electric standard developed by Institute of Electrical and Electronics Engineers, or IEEE. Unless otherwise specified by the Commission, DEC shall use the applicable provisions in the latest revised version of the referenced publications listed below as standards of accepted good engineering practice:

- A. National Electrical Safety Code, ANSI C2-2002;
- B. National Electrical Code, ANSI/NFPA 70—2005;
- C. American National Standard for Electric Meters—Code for Electricity Metering, ANSIC12.1—2001;
- D. American Standard Requirements, Terminology and Test Code for Instrument Transformers, ANSI/IEEE C57.13—1993;
- E. Standard for Interconnecting Distributed Resources with Electric Power Systems, IEEE Standard 1547—2003;
- F. Conformance Test Procedures for Equipment Interconnecting Distributed Resources with Electric Power Systems, IEEE Standard 1547.1—2005; and
- G. NEMA Standards Publication TP 1-2002.

“Interconnection member” means an entity that proposes to interconnect a small generator facility to an electric distribution system.

Interconnection:

- (a) “Interconnection equipment” means a group of components or integrated system, owned by either the Interconnection Member, or the Local Electric Power System (DEC), to accommodate the interconnection of a small generator facility with a local electric power system or an electric distribution system.
- (b) Interconnection Member “Interconnection facilities/equipment” means facilities and equipment, owned by the Interconnection Member, required by DEC to interconnect the small generation facility to the DEC Distribution System and includes all interface equipment including switchgear, protective devices, inverters or other interface devices, including equipment installed as part of an integrated equipment package that includes a generator or other electric source.
- (c) DEC “Interconnection facilities” includes all facilities and equipment, owned by DEC, between the small generator Interconnection Member's Interconnection Facilities and the electric distribution system and includes modifications, additions, or upgrades that are necessary to physically and electrically interconnect the small generator facility to the electric distribution system.
- (d) The Interconnection Member Interconnection Facilities and the DEC Interconnection facilities are connected at the Point of Interconnection.

“Interconnection request” means an applicant’s request on a form approved by DEC for the interconnection of a new small generator facility, or to increase the capacity or operating characteristics of an existing small generator facility that is interconnected with the DEC’s electric distribution system.

“Interconnection study” means an interconnection feasibility study, interconnection system impact study, or interconnection facilities study as described in Section 12 of this document.

“Line section” means that portion of a DEC electric distribution system connected to an interconnection member, bounded by automatic sectionalizing devices or the end of the distribution line.

“Local electric power system” means those facilities that deliver electric power to a load that are contained entirely within a single premises or group of premises, and has the same meaning as the term local electric power system as defined in section 3.1.6.2 of IEEE Standard 1547.

“Minor equipment modification” means a change to the proposed small generator facility that does not have a significant impact on safety or reliability of the electric distribution system.

“Nameplate capacity” means the maximum rated output of a generator, prime mover, Inverter AC, or other electric power production equipment under specific conditions designated by the manufacturer and is usually listed on a nameplate physically attached to the power production equipment.

“Nationally recognized testing laboratory (NRTL)” means a qualified private organization recognized by the Occupational Safety and Health Administration to perform independent safety testing and product certification.

“Parallel operation” means the sustained state of operation over 100 milliseconds which occurs when a small generator facility is connected electrically to the electric distribution system and thus has the ability for electricity to flow from the small generator facility to the electric distribution system.

“Point of interconnection” means the point where the Interconnection Member's Interconnection Facilities are electrically connected to DEC's Interconnection Facilities or the electric distribution system, having the same meaning as the term “point of common coupling” as defined in section 3.1.13 of IEEE Standard 1547.

“Primary line” means a distribution line rated at greater than 600 volts.

“Queue position” means the order of a completed interconnection request, relative to all other pending completed interconnection requests, that is established based upon the date and time of receipt of the completed interconnection request by DEC.

“Radial distribution circuit” means a circuit configuration in which independent feeders branch out radially from a common source of supply.

“Rate X or Service Classification X” refers to a Commission approved, cogeneration and small power production DEC tariff that is available to members throughout the territory served by the Company in the State of Delaware and is applicable to purchases

of non-renewable generated electricity by the Company from generators or small power producers which meet Federal qualifying standards and have a generating capacity of 1,000 kW or less.

“Scoping meeting” means a meeting between the applicant and DEC conducted for the purpose of discussing alternative interconnection options, exchanging information including any electric distribution system data and earlier study evaluations that would be reasonably expected to impact interconnection options, analyzing information, and determining the potential feasible points of interconnection.

“Secondary line” means a service line subsequent to the primary line that is rated for 600 volts or less, also referred to as the member’s service line.

“Shared transformer” means a transformer that supplies secondary source voltage to more than one member.

Small generator facility:

- (a) “Small generator facility” means the equipment used to generate or store electricity that operates in parallel with the electric distribution system with a nameplate capacity equal to or less than 10 MW.
- (b) “Small generator facility” includes an electric generator, prime mover, and the interconnection equipment required to safely interconnect with the electric distribution system or local electric power system.

“Spot network” means a type of electric distribution system that uses two or more inter-tied transformers to supply an electrical network circuit generally used to supply power to a single member or a small group of members and has the same meaning as the term is defined in 4.1.4 of IEEE Standard 1547.

“Standard small generator interconnection agreement” means a set of standard forms approved by the Commission of interconnection agreements which are applicable to interconnection requests pertaining to small generating facilities.

“UL Standard 1741” means the Underwriters Laboratories’ standard titled “Inverters Converters, and Controllers for Use in Independent Power Systems”, November 7, 2005 edition.

“Witness test” means, for lab certified or field approved equipment, verification either by an on-site observation or review of documents by DEC that the interconnection installation evaluation required by Section 5.3 of IEEE Standard 1547 and the commissioning test required by Section 5.4 of IEEE Standard 1547 have been adequately performed.

C. Acceptable Standards

1. The technical standard to be used in evaluating all interconnection requests under Level 1, Level 2, Level 3, and Level 4 reviews, unless otherwise provided for in this document, is IEEE Standard 1547.

2. Attachment H to the PJM Interconnection Planning Manual, available from the website www.pjm.com, shall be used to detail and illustrate the interconnection protection requirements that are provided in IEEE Standard 1547.

D. Interconnection Requests

1. Applicants seeking to interconnect a small generator facility shall submit an interconnection request using a standard form approved by DEC that owns the electric distribution system to which interconnection is sought.

E. Interconnection Request Processing Fees

1. The interconnection request processing fees are located in Topic IV of this document.
2. DEC shall specify the interconnection processing fees charged in its application forms.

F. General Requirements

1. When an interconnection request for a small generator facility includes multiple energy production devices at a site for which the applicant seeks a single point of interconnection, the interconnection request shall be evaluated on the basis of the aggregate nameplate capacity of the multiple devices.
2. When an interconnection request is for an increase in capacity for an existing small generator facility, the interconnection request shall be evaluated on the basis of the new total nameplate capacity of the small generator facility.
3. Utility Provided Information.
 - (a) DEC shall designate a contact person and provide contact information on its website and for the Commission's website for submission of all interconnection requests and from whom information on the interconnection request process and the utility's electric distribution system can be obtained.
 - (b) In appropriate circumstances, DEC may require an applicant to execute an appropriate confidentiality agreement prior to release or access to confidential or restricted information.
4. When an interconnection request is deemed complete, a modification other than a minor equipment modification that is not agreed to in writing by DEC, shall require submission of a new interconnection request.
5. When an applicant is not currently a member of DEC at the location for the proposed generation facility, upon request from the utility the applicant shall provide proof of site control evidenced by a property tax bill, deed, lease agreement, contract, or other acceptable document.

6. Connection of Multiple Small Generators by Single Interconnection.
 - (a) To minimize the cost of interconnecting multiple small generator facilities, DEC or the applicant may propose a single point of interconnection for multiple small generator facilities located at a single site.
 - (b) If an applicant rejects DEC proposal for a single point of interconnection, the applicant shall pay any additional cost of providing separate points of interconnection for each small generator facility.
 - (c) If DEC unreasonably rejects a member proposal for a single point of interconnection without providing a written technical explanation, the utility shall pay any additional cost of providing separate points of interconnection for each small generator facility.

7. Electrical Isolation of Generators.
 - (a) Small generator facilities shall be capable of being isolated from DEC's distribution system.
 - (b) For small generator facilities interconnecting to a primary line, the isolation shall be by means of a lockable, visible-break isolation device accessible by the utility.
 - (c) For small generator facilities interconnecting to a secondary line, the isolation shall be by means of a lockable isolation device whose status is clearly indicated and is accessible by the utility.
 - (d) The isolation device shall be installed, owned and maintained by the owner of the small generation facility and located electrically between the small generation facility and the point of interconnection.
 - (e) A draw-out type circuit breaker with a provision for padlocking at the draw-out position satisfies the requirement for an isolation device.

8. Use of Lockbox for Access to Isolation Device.
 - (a) An interconnection member may elect to provide DEC access to an isolation device that is contained in a building or area that may be unoccupied and locked or not otherwise readily accessible to the utility, by installing a lockbox provided by DEC that shall allow ready access to the isolation device.
 - (b) The lockbox shall be in a location that is readily accessible by the utility and the interconnection member shall permit DEC to affix a placard in a location of its choosing that provides clear instructions to utility operating personnel on access to the isolation device.
 - (c) In the event the interconnection member fails to comply with the terms of this section and DEC needs to gain access to the isolation device, the utility shall not be held liable for any damages resulting from any necessary utility action to isolate the small generator.

9. Metering.
 - (a) Any metering necessitated by a small generator interconnection shall be installed, operated and maintained in accordance with the applicable DEC tariff.
 - (b) Any small generator metering requirements shall be clearly identified as part of the standard small generator interconnection agreement executed by the interconnection member and DEC.

10. Utility Monitoring and Control of Small Generator.
 - (a) DEC monitoring and control of a small generator facility shall be required only if the nameplate rating is greater than 2 MW, with the exception of the normal data collection for monthly meter reading with 'Advanced' or 'Smart' meters.
 - (b) Any monitoring and control requirements shall be consistent with DEC's published requirements and shall be clearly identified as part of an interconnection agreement executed by the interconnection member and the utility.

11. Witness Test of Small Generator.
 - (a) DEC shall have the option of performing a witness test after construction of the small generator facility is completed.
 - (b) The applicant shall provide the utility at least 5 business days' notice of the planned commissioning test for the small generator facility.
 - (c) If DEC elects to perform a witness test, the utility shall contact the applicant to schedule the witness test at a mutually agreeable time within 10 business days of the scheduled commissioning test.
 - (d) If DEC does not perform the witness test within 10 business days of the commissioning test, the witness test is deemed waived unless the utility and applicant agree to extend the time for conducting the witness test.
 - (e) If the results of the witness test are not acceptable to the utility, the applicant shall address and resolve any deficiencies within 30 business days, which may be extended upon the request of the applicant prior to the expiration of the 30 business day period. A request for extension may not be unreasonably denied by DEC's.
 - (f) If the applicant fails to address and resolve the deficiencies to the satisfaction of the utility, the interconnection request shall be deemed withdrawn.
 - (g) If a witness test is not performed by DEC or an entity approved by the utility, the applicant shall satisfy the interconnection test specifications and requirements set forth in Section 5 of IEEE Standard 1547.
 - (h) For interconnection equipment that has not been lab certified or field approved under Section 7, the witness test shall also include the verification by the utility of the on-site design tests as required by Section 5.1 of IEEE Standard 1547 and of production tests required by Section 5.2 of IEEE Standard 1547.
 - (i) All tests verified by DEC are to be performed in accordance with the test procedures specified in IEEE Standard 1547.1.
 - (j) The applicant shall, if requested by the utility, provide a copy of all documentation in its possession regarding testing conducted under IEEE Standard 1547.1.

12. Interconnection Studies and Applicant Information.
 - (a) If requested by the applicant, DEC shall provide the applicant copies of any interconnection studies performed in analyzing an interconnection request.
 - (b) An applicant may provide any other prospective applicant copies of interconnection studies to aide in streamlining a future utility review.
 - (c) DEC has no obligation to provide any prospective applicant any information regarding prior interconnection requests, including a prior applicant's name, copies of prior interconnection studies performed by the utility, or any other information regarding a prior applicant or request.

G. Lab Certified and Field Approved Equipment

1. An interconnection request may be eligible for expedited interconnection review if the small generator facility uses lab certified or field approved interconnection equipment.
2. Interconnection equipment shall be deemed to be lab certified upon establishment of the following:
 - (a) The interconnection equipment has been tested in accordance IEEE Standard 1547.1 in compliance with the appropriate codes and standards referenced in Section 7 (B7) by any NRTL recognized by the United States Occupational Safety and Health Administration to test and certify interconnection equipment under the relevant codes and standards listed in §B(7).
 - (b) The interconnection equipment has been labeled and is publicly listed by the NRTL at the time of the interconnection application.
 - (c) The NRTL testing the interconnection equipment makes readily available, such as by posting on its website, copies of all test standards and procedures utilized in performing equipment certification, and, with applicant approval, the test data itself.
 - (d) The applicant verifies that the intended use of the interconnection equipment falls within the use or uses for which the interconnection equipment was labeled, and listed by the NRTL.
 - (e) If the interconnection equipment is an integrated equipment package such as an inverter, then the applicant shall show that the generator or other electric source being utilized is compatible with the interconnection equipment and is consistent with the testing and listing specified for this type of interconnection equipment.
 - (f) If the interconnection equipment includes only interface components such as switchgear, multi-function relays, or other interface devices, then the applicant shall show that the generator or other electric source being utilized is compatible with the interconnection equipment and is consistent with the testing and listing specified for this type of interconnection equipment.
 - (g) To meet the requirements for lab certification, interconnection equipment shall be:
 - i. Evaluated by a NRTL in accordance with the following codes and standards:
 - IEEE Standard 1547, including use of IEEE Standard 1547.1 testing protocols to establish conformity; and
 - National Electrical Code; and
 - ii. Certified by Underwriters Laboratories under UL Standard 1741.
 - (h) Lab certified interconnection equipment may not require further design testing or production testing, as specified by Sections 5.1 and 5.2 of IEEE Standard 1547, or additional interconnection equipment modification to meet the requirements for expedited review; however, nothing herein shall preclude the need for an interconnection installation evaluation, commissioning tests or periodic testing as specified by Sections 5.3, 5.4 and 5.5 of IEEE Standard 1547 or for a witness test that may be conducted by a utility.
 - (i) To meet the requirements for lab certification, interconnection equipment shall be tested and listed by a NRTL in accordance with the codes and standards listed in this section as those codes and standards appeared on the date when the interconnection equipment was manufactured.
 - (j) Interconnection equipment manufactured prior to January 1, 2007 do not require testing and listing based on IEEE Standard 1547.1.

3. Interconnection equipment shall be deemed to be field approved if within the previous 36 months of the date of the interconnection request, it has been previously approved for use with the proposed small generator facility and the following criteria are met:
 - (a) DEC has previously approved interconnection equipment identical to that being proposed under the Level 4 study review process described in Section 12 in a materially identical system application, or the utility has agreed to accept a Level 4 study review conducted for identical interconnection equipment and system application by another utility; and
 - (b) The prior approval process included a successful witness test; and
 - (c) The applicant provided as part of its interconnection request the following:
 - i. A copy of the final certificate of completion from the prior approval process;
 - ii. A written statement that the proposed interconnection equipment is identical to what was previously approved; and
 - iii. Documentation or drawings indicating the system interconnection details.

H. Determination of Level of Utility Review of Interconnection Request

1. DEC shall determine on an expedited basis the level of review required for an interconnection request.
2. DEC shall use a **Level 1** procedure to evaluate an interconnection request to connect an inverter-based small generation facility when:
 - (a) The small generator facility has a nameplate capacity of 10 kW or less; and
 - (b) The member interconnection equipment is lab certified.
3. DEC shall use a **Level 2** procedure to evaluate an interconnection request when:
 - (a) The small generation facility has a nameplate capacity rating of 2 MW or less;
 - (b) The interconnection equipment is lab certified or field approved; and
 - (c) The proposed interconnection is a radial distribution circuit; or a spot network limited to service one member; or
 - (d) Alternatively, the small generator facility was reviewed under Level 1 review procedures but not approved and the applicant has submitted a new interconnection request for consideration.
4. DEC shall use a **Level 3** review procedure to evaluate an interconnection request to area networks and radial distribution circuits when electric power is not exported to the electric distribution system based on the following criteria:
 - (a) For interconnection requests to the load side of an area network:
 - i. The nameplate capacity of the small generator facility is less than or equal to 50 kW;
 - ii. The proposed small generator facility utilizes a lab certified inverter-based equipment package;
 - iii. The small generator facility utilizes reverse power relays and/or other protection functions that prevent the export of power into the area network;
 - iv. The aggregate of all generation on the area network does not exceed the

system, except for metering, is not required to accommodate the small generator facility.

2. DEC in conducting a Level 1 interconnection review shall:
 - (a) Within 5 business days after receipt of the interconnection request, inform the applicant that the interconnection request is:
 - i. Complete; or
 - ii. Incomplete and what materials are missing; and
 - (b) Within 15 business days after the utility notifies the applicant that the application is complete in paragraph (1), verify that the small generator facility equipment can be interconnected safely and reliably under Section 9 (A).
3. Unless the utility determines and demonstrates that a small generator facility cannot be interconnected safely or reliably to its electric distribution system, the utility shall approve the interconnection request subject to the following conditions:
 - (a) The small generator facility has been approved by local or municipal electric code officials with jurisdiction over the interconnection;
 - (b) A certificate of completion has been returned to DEC;
 - (c) The witness test has been successfully completed or waived by the utility;
 - (d) The applicant has signed a standard small generator interconnection agreement.
4. If an applicant does not sign the standard small generator interconnection agreement within 30 business days after receipt from DEC, the interconnection request be deemed withdrawn unless the applicant requests to have the deadline extended. A request for extension may not be unreasonably denied by the utility.
5. Level 1 Review Failure.
 - (a) If the small generator facility is not approved under a Level 1 review, DEC shall provide the applicant a letter explaining its reasons for denying the interconnection request.
 - (b) When a small generator facility is not approved under a Level 1 review, the applicant may submit a new interconnection request for consideration under Level 2, Level 3 or Level 4 procedures.

J. Level 2 Review

1. DEC shall evaluate a Level 2 small generator facility for the potential for adverse system impacts using the following:
 - (a) For interconnection of a proposed small generator facility:
 - i. To a radial distribution circuit, the aggregated generation on the circuit, including the proposed small generator facility, may not exceed 15% of the line section annual peak load most recently measured at the substation or calculated for the line section; or
 - (b) To a spot network:
 - i. When the interconnection of a proposed small generator facility is to the load side of spot network protectors, the proposed small generator facility shall utilize an inverter-based equipment package;
 - ii. The applicant's interconnection equipment proposed for the small generator facility shall be lab certified or field approved; and
 - iii. A small generating facility, when aggregated with other generation on

the spot network, may not exceed 5% of a spot network's maximum load if the spot network serves more than one member; and

- (c) Fault current limitations:
 - i. The proposed small generator facility, in aggregation with other generation on the distribution circuit, may not contribute more than 10% to the electric distribution circuit's maximum fault current at the point on the primary line nearest the point of interconnection;
 - ii. The proposed small generator facility, in aggregate with other generation on the distribution circuit, may not cause any distribution protective devices and equipment including substation breakers, fuse cutouts, and line reclosers, or other member equipment on the electric distribution system to be exposed to fault currents exceeding 90% of the short circuit interrupting capability; and
 - iii. The interconnection request may not request interconnection on a circuit that already exceeds 90% of the short circuit interrupting capability; and
 - (d) The proposed small generator facility's point of interconnection may not be on a transmission line;
 - (e) When a member-generator facility is to be connected to 3 phase, 3 wire primary utility distribution lines, a 3 phase or single-phase generator shall be connected phase-to-phase;
 - (f) When a member-generator facility is to be connected to 3 phase, 4 wire primary utility distribution lines, a 3 phase or single phase generator will be connected line-to-neutral and will be effectively grounded;
 - (g) When the proposed small generator facility is to be interconnected on single-phase shared secondary line, the aggregate generation capacity on the shared secondary line, including the proposed small generator facility, shall not exceed 20 kW;
 - (h) When a proposed small generator facility is single-phase and is to be interconnected on a center tap neutral of a 240 volt service, its addition may not create an imbalance between the two sides of the 240 volt service of more than 20% of the nameplate rating of the service transformer;
 - (i) A small generator facility, in aggregate with other generation interconnected to the distribution side of a substation transformer feeding the circuit where the small generator facility proposes to interconnect, may not exceed 10 MW in an area where there are known or posted transient stability limitations to generating units located in the general electrical vicinity; and
 - (j) Except as permitted by an additional review in Section 10 (G), no modification or construction of additional facilities by DEC of its distribution system, with the exception of metering, shall be required to accommodate the small generator facility.
2. DEC shall, within 5 business days after receipt of the interconnection request, inform the applicant that the interconnection request is:
- (a) Complete; or
 - (b) Incomplete and what materials are missing;
3. Queue Position.
- (a) When an interconnection request is complete, DEC shall assign a queue position if there is more than one interconnection request pending for the same line section.
 - (b) The queue position of the interconnection request shall be used to determine the

- potential adverse system impact of the small generator facility based on the relevant screening criteria.
- (c) The utility shall notify the applicant of any other higher queue position applicants on the same line section or spot network for which interconnection is sought.
 - (d) Queue position may not be forfeited or otherwise impacted by the submission of a dispute under the provisions of Section 13.
4. When DEC determines additional information is required to complete an evaluation:
- (a) The utility shall request the information;
 - (b) The time necessary to complete the evaluation may be extended, but only to the extent of the delay required for receipt of the additional information; and
 - (c) When additional information is required, the utility may not revert to the start of the review process or alter the applicant's queue position.
5. Within 20 business days after the utility notifies the applicant it has received a completed interconnection request, DEC shall:
- (a) Evaluate the interconnection request using the Level 2 screening criteria;
 - (b) Review the applicant's analysis, if provided by applicant, using the same criteria;
 - (c) Provide the applicant with DEC's evaluation, including a comparison of the results of its own analyses with those of applicant, if applicable; and
 - (d) When DEC does not have a record of receipt of the interconnection request and the applicant can demonstrate that the original interconnection request was delivered, expedite its review to complete the evaluation of the interconnection request within 20 business days.
6. The utility is not obligated to comply with the 20 business day limit of Section 10 E) for reviewing the interconnection request until such time as the utility has completed the review of all other interconnection requests that have a higher queue position.
7. Failure to Meet Level 2 Criteria.
- (a) Additional review may be appropriate when a small generator facility has failed to meet one or more of the Level 2 criteria of Section 10 (A).
 - (b) DEC shall:
 - i. Offer to perform additional review to determine whether minor modifications to the electric distribution system would enable the interconnection to be made consistent with safety, reliability, and power quality criteria; and
 - ii. Provide the applicant with a nonbinding, good faith estimate of the costs of additional review and minor modifications.
 - (c) DEC shall undertake the additional review only if the applicant agrees within 10 business days to pay for the cost of the review, which may be extended at the request of the applicant. A request for extension may not be unreasonably denied by the utility.
 - (d) If the review identifies the need for modifications to the distribution system, the utility shall make the necessary modifications only if the interconnection member agrees to pay for the cost of the modifications.

8. Interconnection Agreement.
 - (a) When DEC determines that the interconnection request passes the Level 2 screening criteria, or fails one or more of the Level 2 screening criteria but determines that the small generator facility can be interconnected safely and reliably, the utility shall provide the applicant a standard small generator interconnection agreement within 5 business days after the determination.
 - (b) The applicant shall have either 30 calendar days, or another mutually agreeable timeframe after receipt of the standard small generator interconnection agreement, to sign and return the standard small generator interconnection agreement.
 - (c) If the applicant does not sign the standard small generator interconnection agreement within 30 calendar days, the request shall be deemed withdrawn unless the applicant and utility mutually agree to extend the time period for executing the standard small generator interconnection agreement prior to the expiration of the 30 business day period. A request for extension may not be unreasonably denied by DEC.
 - (d) After the standard small generator interconnection agreement is signed by the applicant and utility, interconnection of the small generator facility shall proceed according to any milestones agreed to by the applicant and utility in the standard small generator interconnection agreement.
 - (e) The interconnection agreement will not be final until:
 - i. Any milestones agreed to in the standard small generator interconnection agreement are satisfied;
 - ii. The small generator facility is approved by electric code officials with jurisdiction over the interconnection;
 - iii. The applicant provides a certificate of completion to the utility; and
 - iv. There is a successful completion of the witness test, if conducted by DEC.
9. Level 2 Review Failure.
 - (a) If the small generator facility is not approved under a Level 2 review, DEC shall provide the applicant a letter explaining its reasons for denying the interconnection request.
 - (b) The applicant may submit a new interconnection request for consideration under a Level 3 or Level 4 interconnection review; however, the queue position assigned to the Level 2 interconnection request shall be retained provided the request is made within 15 business days of notification that the current Level 2 interconnection request is denied.

K. Level 3 Review

1. DEC shall use the Level 3 review procedure for an interconnection request that meets the Level 3 criteria in Section 8.
2. Queue Position.
 - (a) Once the interconnection request is deemed complete by the utility, the utility shall assign a queue position based upon the date and time the interconnection request is determined to be complete if there is more than one interconnection request pending for the same line section.
 - (b) The queue position of each interconnection request shall be used to determine the

- potential adverse system impact of the small generator facility based on the relevant screening criteria.
- (c) DEC shall notify the applicant of any other higher queue position applicants on the same radial line or area network that the applicant is seeking to interconnect to.
 - (d) Queue position may not be forfeited or otherwise impacted by any pending dispute submitted under the provisions of Section 14.
3. Interconnection requests meeting the requirements set forth in Section 8 for non-exporting small generator facilities interconnecting to an area network shall be presumed by the utility to be appropriate for interconnection. DEC shall process the interconnection request to area networks using the following procedures:
- (a) DEC shall evaluate the interconnection request under Level 2 interconnection review procedures as set forth in Section 10 (C) except that the utility shall have 25 business days to conduct an area network impact study to determine any potential adverse system impacts of interconnecting to the utility's area network; however, the utility may not be obligated to meet the 25 business day limit for reviewing the interconnection request until such time as the utility has completed the review of all other interconnection requests that have a higher queue position.
 - (b) In the event the area network impact study identifies potential adverse system impacts, DEC may determine at its sole discretion that it is inappropriate for the small generator facility to interconnect to the area network in which case the interconnection request shall be denied; however, the applicant may elect to submit a new interconnection request for consideration under Level 4 procedures in which case the queue position assigned to the Level 3 interconnection request will be retained provided the request is made within 15 business days of notification that the current application is denied.
 - (c) DEC will conduct the area network impact study at its own expense.
 - (d) In the event the utility denies the interconnection request, the utility shall provide the applicant with a copy of its area network impact study and written justification for denying the interconnection request.
4. For an interconnection request meeting the requirements of Section 8 for non-exporting small generator facilities interconnecting to a radial distribution circuit, DEC shall:
- (a) Evaluate the interconnection request using the Level 2 review in Section 10; and
 - (b) Approve the interconnection request if all of the applicable Level 2 screens are satisfied except that the peak line section value indicated in Section 10 (A) shall be 25% instead of 15%.
5. Interconnection Agreement.
- (a) When a small generator facility that satisfies the criteria in Section 11 (C & D), the utility shall approve the interconnection request and provide a standard interconnection agreement for the applicant to sign.
 - (b) The applicant shall have 30 calendar days, or other mutually agreeable timeframe after receipt of the standard small generator interconnection agreement, to sign and return the standard small generator interconnection agreement.
 - (c) If the applicant does not sign the standard small generator interconnection agreement within 30 calendar days, the interconnection request shall be deemed withdrawn unless the applicant and utility mutually agree to extend the time period

for executing the standard small generator interconnection agreement prior to the expiration of the 30-business day period. A request for extension may not be unreasonably denied by DEC.

- (d) After the standard small generator interconnection agreement is signed by the applicant and utility, interconnection of the small generator facility shall proceed according to any milestones agreed to by the applicant and utility in the standard small generator interconnection agreement.
 - (e) The interconnection agreement will not be final until:
 - i. Any milestones agreed to in the standard small generator interconnection agreement are satisfied;
 - ii. The small generator facility is approved by electric code officials with jurisdiction over the interconnection;
 - iii. The applicant provides a certificate of completion to the utility; and
 - iv. There is a successful completion of the witness test, if conducted by DEC.
6. Level 3 Review Failure.
- (a) If the small generator facility is not approved under a Level 3 review, the utility shall provide the applicant a letter explaining its reasons for denying the interconnection request.
 - (b) If the small generator facility is not approved under a Level 3 review, the applicant may submit a new interconnection request for consideration under the Level 4 procedures; however, the queue position assigned to the Level 3 interconnection request shall be retained provided the request is submitted within 15 business days of the notice that the current Level 3 request was not approved.

L. Level 4 Study Review

1. DEC shall use the Level 4 study review procedure for an interconnection request that meets the Level 4 criteria in Section 8.
2. Interconnection Request.
 - (a) Within 5 business days from receipt of an interconnection request, the utility shall notify the applicant whether the request is
 - i. Complete; or
 - ii. Incomplete.
 - (b) When the interconnection request is not complete:
 - i. DEC shall provide the applicant a written list detailing information that shall be provided to complete the interconnection request;
 - ii. The applicant shall have 10 business days, which may be extended at the request of the applicant and not unreasonably denied by the utility, to provide appropriate data in order to complete the interconnection request or the interconnection request shall be considered withdrawn; and
 - iii. The interconnection request shall be deemed complete:
 - (i) When the required information has been provided by the applicant, or
 - (ii) The utility and applicant have agreed that the applicant may provide additional information at a later time.

3. Queue Position.
 - (a) When an interconnection request is complete, the utility shall assign a queue position if there is more than one interconnection request pending for the same line section.
 - (b) DEC shall use the queue position of an interconnection request to determine the cost responsibility necessary for the facilities to accommodate the interconnection.
 - (c) The utility shall notify the applicant of other higher-queued applicants on the same line section of the new interconnection request.
 - (d) Any required interconnection studies shall not begin until the utility has completed its review of all other interconnection requests that have a higher queue position.
 - (e) Queue position shall not be forfeited or otherwise impacted by any pending dispute submitted under the provisions of Section 13.

4. Scoping Meeting.
 - (a) By mutual agreement of DEC and applicant, the scoping meeting, interconnection feasibility study, interconnection impact study, or interconnection facilities studies provided for in a Level 4 review and discussed in this section may be waived.
 - (b) If agreed to by the utility and applicant, a scoping meeting will be held within 10 business days, or other mutually agreed to time, after the utility has notified the applicant that the interconnection request is deemed complete, or the applicant has requested that its interconnection request proceed after failing the requirements of a Level 2 review or Level 3 review.
 - (c) The purpose of the meeting is to review the interconnection request, existing studies relevant to the interconnection request, and the results of the Level 1, Level 2, or Level 3 screening criteria.
 - (d) When the utility and applicant agree at a scoping meeting that an interconnection feasibility study shall be performed, the utility shall provide to the applicant, no later than 5 business days after the scoping meeting:
 - i. An interconnection feasibility study agreement,
 - ii. An outline of the scope of the study, and
 - iii. A nonbinding, good faith estimate of the cost to perform the study.
 - (f) When the applicant and DEC agree at a scoping meeting that an interconnection feasibility study is not required, the utility shall provide to the applicant, no later than 5 business days after the scoping meeting:
 - i. An interconnection system impact study agreement,
 - ii. An outline of the scope of the study, and
 - iii. A nonbinding, good faith estimate of the cost to perform the study.
 - (g) When the utility and applicant agree at the scoping meeting that an interconnection feasibility study and system impact study are not required, the utility shall provide to the applicant, no later than 5 business days after the scoping meeting:
 - i. An interconnection facilities study agreement,
 - ii. An outline of the scope of the study, and
 - iii. A nonbinding, good faith estimate of the cost to perform the study.

5. Interconnection Feasibility, Impact, and Facilities Studies.
 - (a) Interconnection Feasibility Study.
 - i. An interconnection feasibility study shall include any necessary analyses for the purpose of identifying a potential adverse system impact to DEC's electric distribution system that would result from the interconnection from among the

following:

- (i) Initial identification of any circuit breaker short circuit capability limits exceeded as a result of the interconnection;
 - (ii) Initial identification of any thermal overload or voltage limit violations resulting from the interconnection;
 - (iii) Initial review of grounding requirements and system protection; and
 - (iv) Description and nonbinding estimated cost of facilities required to interconnect the small generator facility to the utility's electric distribution system in a safe and reliable manner.
 - ii. When an applicant requests that the interconnection feasibility study evaluate multiple potential points of interconnection, additional evaluations may be required. Additional evaluations shall be conducted at the expense of the applicant.
 - iii. An interconnection system impact study is not required when the interconnection feasibility study concludes there is no adverse system impact, or when the study identifies an adverse system impact and the utility is able to identify a remedy without the need for an interconnection system impact study.
 - iv. DEC and applicant shall use an interconnection feasibility study agreement form approved by the Commission.
 - v. The utility shall avoid duplicating previously conducted interconnection studies to the extent possible.
- (b) Interconnection Impact Study.
- i. A distribution interconnection system impact study shall be performed when a potential distribution system adverse system impact is identified in the interconnection feasibility study.
 - ii. Scope of Interconnection System Impact Study.
 - (i) An interconnection system impact study shall evaluate the impact of the proposed interconnection on both the safety and reliability of the utility's electric distribution system.
 - (ii) The interconnection system impact study shall identify and detail the system impacts that result when a small generator facility is interconnected without project or system modifications, focusing on the adverse system impacts identified in the interconnection feasibility study, or potential impacts including those identified in the scoping meeting.
 - (iii) The interconnection system impact study shall consider all generating facilities that, on the date the interconnection system impact study is commenced, are directly interconnected with the utility's system, have a pending higher queue position to interconnect to the system, or have a signed a standard small generator interconnection agreement.
 - (iv) As part of its impact study, the utility shall agree to evaluate and consider any separate studies prepared by the applicant that evaluate alternatives for interconnecting the small generator facility including the applicant's assessment of potential impacts of the small generator facility on the electric distribution system.
 - (v) DEC shall provide the applicant with the utility's final impact study

evaluation including a comparison of the results of its own analyses with those provided by the applicant.

- iii. Within 5 business days of transmittal of the interconnection feasibility study report, the utility shall send the applicant:
 - (i) An interconnection system impact study agreement using a form approved by the Commission;
 - (ii) An outline of the scope of the interconnection system impact study, and
 - (iii) A good faith estimate of the cost to perform the study.
 - iv. The impact study shall include any necessary elements from among the following:
 - (i) A load flow study;
 - (ii) Identification of affected systems;
 - (iii) An analysis of equipment interrupting ratings;
 - (iv) A protection coordination study;
 - (v) Voltage drop and flicker studies;
 - (vi) Protection and set point coordination studies;
 - (vii) Grounding reviews; and
 - (viii) Impact on system operation.
 - v. An interconnection system impact study shall consider any necessary criteria from among the following:
 - (i) A short circuit analysis;
 - (ii) A stability analysis;
 - (iii) Alternatives for mitigating adverse system impacts on affected systems;
 - (iv) Voltage drop and flicker studies;
 - (v) Protection and set point coordination studies; and
 - (vi) Grounding reviews.
 - vi. The final interconnection system impact study shall provide the following:
 - (i) The underlying assumptions of the study;
 - (ii) The results of the analyses;
 - (iii) A list of any potential impediments to providing the requested interconnection service;
 - (iv) Required distribution upgrades; and
 - (v) A nonbinding good faith estimate of cost and time to construct any required distribution upgrades.
- (c) Interconnection Facilities Study.
- i. Within 5 business days of completion of the interconnection system impact study, the utility shall provide to the applicant:
 - (i) A report of the impact study;
 - (ii) An interconnection facilities study agreement using a form approved by the Commission;
 - (iii) An outline of the scope of the interconnection facilities study; and
 - (iv) A nonbinding good faith estimate of the cost to perform the facilities study.
 - ii. The interconnection facilities study shall identify:
 - (i) The electrical switching configuration of the equipment, including transformer, switchgear, meters and other station equipment;
 - (ii) The nature and estimated cost of the utility's interconnection

facilities and distribution upgrades necessary to accomplish the interconnection, including engineering, procurement, construction, and overhead; and

- (iii) An estimate of the time required to complete the construction and installation of the facilities.
 - iii. Third Party Design or Construction of Interconnection Facilities.
 - (i) The applicant and DEC may agree to permit an applicant to separately arrange for a third party to design and construct the required interconnection facilities.
 - (ii) DEC may review and approve the design of the facilities under the interconnection facilities study agreement.
 - (iii) When the applicant and utility agree to separately arrange for design and construction, and consistent with security and confidentiality requirements, the utility shall make all relevant information and required specifications available to the applicant to permit the applicant to obtain an independent design and cost estimate for the interconnection facilities.
 - (iv) The interconnection facilities shall be built in accordance with the specifications.
 - iv. Upon completion of the interconnection facilities study, and with the agreement of the applicant to pay for the interconnection facilities and distribution upgrades identified in the interconnection facilities study, the utility shall provide the applicant with a standard small generator interconnection agreement within 5 business days.
 - v. Delay in Electric Distribution System Upgrades.
 - (i) In the event that electric distribution system upgrades are identified in the impact study that will be required to be added only in the event that higher queue position members not yet interconnected eventually will complete and interconnect their generation facilities, an applicant may elect to interconnect without paying for such upgrades at the time of the interconnection under the condition that the member shall pay for such upgrades at the time the higher queue position member is ready to interconnect.
 - (ii) If the applicant does not pay for the cost of the electric distribution system upgrades at that time, the utility shall require the member to immediately disconnect its generating facility so that interconnection of the higher-queued member can be accommodated.
6. Interconnection Agreement.
- (a) When DEC determines, as a result of the interconnection studies conducted under a Level 4 review, that it is appropriate to interconnect the small generator facility, the utility shall provide the applicant with a standard small generator interconnection agreement.
 - (b) The applicant shall have either 30 calendar days, or another mutually agreeable timeframe after receipt of the standard small generator interconnection agreement, to sign and return the standard small generator interconnection agreement.
 - (c) If the applicant does not sign the standard small generator interconnection

agreement within 30 calendar days, the request shall be deemed withdrawn unless the applicant and utility mutually agree to extend the time period for executing the standard small generator interconnection agreement prior to the expiration of the 30-business day period. A request for extension may not be unreasonably denied by DEC.

- (d) After the standard small generator interconnection agreement is signed by the applicant and utility, interconnection of the small generator facility shall proceed according to any milestones agreed to by the applicant and utility in the standard small generator interconnection agreement.
 - (e) The interconnection agreement will not be final until:
 - i. Any milestones agreed to in the standard small generator interconnection agreement are satisfied;
 - ii. The small generator facility is approved by electric code officials with jurisdiction over the interconnection;
 - iii. The applicant provides a certificate of completion to DEC; and
 - iv. There is a successful completion of the witness test, if conducted by the utility
7. Level 4 Review Failure. If the interconnection request is denied, DEC shall provide the applicant a letter explaining the reasons for denying the interconnection request.

M. Dispute Resolution

1. The applicant and DEC shall attempt to resolve all disputes regarding interconnection as provided in this section promptly, equitably, and in a good faith manner.
2. Dispute Resolution Before the Commission.
 - (a) When a dispute arises, the applicant or utility may seek immediate resolution through a dispute resolution process approved by the Commission, by providing written notice to the Commission and the other party stating the issues in dispute.
 - (b) Dispute resolution shall be conducted in an informal, expeditious manner to reach resolution with minimal costs and delay.
 - (c) When available, dispute resolution may be conducted by phone.
3. Dispute Resolution by Technical Master.
 - (a) When disputes relate to the technical matters regarding the interconnection process, upon the request of the applicant and utility and at their cost, the Commission may designate a technical master to resolve the dispute.
 - (b) The Commission may designate a Department of Energy National Laboratory, PJM Interconnection, LLC, or a college or university with electric distribution system engineering expertise as the technical master.
 - (c) Upon Commission designation, the applicant and utility shall use the technical master to resolve disputes related to interconnection.
 - (d) Responsibility for the costs for a dispute resolution conducted by the technical master shall be determined either prior to submission of the dispute to the technical master by the applicant and utility, or by the technical master after the resolution of the dispute.

4. Pursuit of dispute resolution may not affect an applicant with regard to consideration of an interconnection request or an applicant's queue position.
5. Any deadline imposed by the Delaware Interconnection Standard, which is directly affected by any issue in dispute, shall be suspended until resolution of the dispute.

N. Record Retention and Reporting Requirements

1. DEC shall retain records of the following for a minimum of three years:
 - (a) The total number of and the nameplate capacity of the interconnection requests received, approved, and denied under Level 1, Level 2, Level 3, and Level 4 reviews;
 - (b) The fuel type, total number and the nameplate capacity of small generator facilities approved in each of the following categories: net metering, emergency standby capable of operating in parallel, behind the meter load offset, combined heat, and power, and other;
 - (c) The number of interconnection requests that were not processed within the deadlines established for Level 1, Level 2, Level 3 and Level 4 reviews;
 - (d) The number of scoping meetings held and the number of feasibility studies, impact studies, and facility studies performed and the fees charged for these studies;
 - (e) The justifications for the actions taken to deny interconnection requests; and
 - (f) Any special operating requirements required in interconnection agreements, which are permitted only for generating facilities with a capacity greater than 2 MW, that are not part of DEC's operating procedures applicable to small generator facilities.
2. DEC shall retain records of interconnection studies it performs to determine the feasibility, system impacts, and facilities required by the interconnection of any small generator facility for a minimum of seven years.
3. DEC shall file no later than April 1 of each year a report entitled "Annual Small Generator Interconnection Report" to the Commission containing the following information for the preceding calendar year:
 - (a) The total number of and the nameplate capacity of the interconnection requests received, approved, and denied under Level 1, Level 2, Level 3, and Level 4 reviews;
 - (b) The fuel type, total number, and total nameplate capacity of small generator facilities approved in each of the following categories: net metering, emergency standby capable of operating in parallel, behind the meter load offset, combined heat, and power, and other;
 - (c) The number of interconnection requests that were not processed within the deadlines established for Level 1, Level 2, Level 3 and Level 4 reviews; and
 - (d) The number of interconnection requests denied and the applicant, the address of the proposed small generator, and the reason for each denial.

4. DEC shall file a notice with the Commission describing any interconnection equipment the utility has deemed field approved for its distribution system within 90 days after granting approval for the interconnection of a small generator facility using the field approved interconnection equipment.

V. Interconnection Request Processing Fees.

Systems under 25 kW:

The application fee is \$50.00 per application for new or upgraded systems 25 kW DC or less. For systems over 25 kW DC the fee will be \$50.00 plus \$1 for each kW DC over the initial 25 kW DC. The application fee for systems where accounts will be aggregated is \$125 per application regardless of kW DC size. All Interconnection Applications submitted to DEC shall be accompanied with the appropriate fee made payable to DEC. The application fee is non-refundable. Applications returned for incomplete or erroneous information will be subject to an additional \$50 application fee when resubmitted. No applications will be considered without the application fee. Returned checks will be assessed an additional fee based on DEC's Returned Check Policy.

Systems over 25 kW:

The application fee is \$125.00 per application for new or upgraded systems 100 kW DC or greater. For systems over 100 kW DC the fee will be \$125.00 plus \$1 for each kW DC over the initial 100 kW DC. All Interconnection Applications submitted to DEC shall be accompanied with the appropriate fee made payable to DEC. The application fee is non-refundable. Applications returned for incomplete or erroneous information will be subject to an additional \$125.00 application fee when resubmitted. No applications will be considered without the application fee. Returned checks will be assessed an additional fee based on DEC's Returned Check Policy.

All renewable-energy generator systems must comply with all applicable safety and performance standards established by the National Electric Code (NEC), IEEE and UL. These systems are also eligible for net metering. **DEC customers with systems greater than 25 kW are required to carry at least \$1 million in liability insurance per occurrence and \$1 million in property-loss insurance. Higher amounts of coverage may be required at the discretion of DEC.**

VI. Applicability

Unless otherwise provided, these technical considerations apply to all Customer-owned generation interconnected with and operating in parallel with the DEC system at voltages up to and including 138 kV. Where multiple generators are connected to the Grid through a single Point of Common Coupling, the sum of the generator ratings will be used to determine the applicability of these Technical Considerations. These technical considerations also apply to NEM (Net Energy Metering) generator interconnections.

A. **Control, Protection and Safety Equipment Requirements Specific to Generators of 25 kW or less.**

All Generator Owner generators 25 kW or less may be single-phase if electric service is single-phase. Customer-owned generators greater than 25 kW must be evaluated by the Company to determine if it can be single-phase. For a three-phase service, single-phase generation will be considered by the Company only during emergency standby and customer's service must be totally isolated from DEC system. The following describes necessary control, protection and safety equipment specific to generators of 25 kW or less connected to Secondary or Primary Voltage Systems:

B. **Control, Protection and Safety Equipment for Generators 25 kW¹ or Less, Connected to Secondary or Primary System**

Generator Size 25 kW, or Less

Generator Disconnect Device	X
Over-Current Trip	X
Over-Voltage Trip	X
Under-Voltage Trip	X
Over/Under Frequency Trip	X
Synchronizing Check ²	Manual or Automatic

Notes:

1. Exporting to the DEC system may require additional operational/protection devices.
2. For synchronous and other type of generators with stand-alone capability

C. Disconnection and Reconnection

The Company may disconnect a distributed generation unit under the following conditions:

1. *Application Termination* - Upon termination of the approved Interconnection Application.
2. *Non Compliance* - For non-compliance with the technical guidelines specified in this document or other requirements contained in the applicable Customer Tariff, provided that the Company has given notice to the Generator Owner and provided the Generator Owner reasonable time (consistent with the condition) to correct such non-compliance. The Company will reconnect the unit only upon receipt of certification from the Generator Owner and verification by the Company that the unit is in compliance. The Company will provide verification within a reasonable time period.
3. *In case of a system emergency or outage of the Company's primary electrical source* - The Generator Owner's generation equipment must be installed and configured so that parallel operation must cease immediately and automatically during outages or loss of the Company's electric source in accordance with these guidelines. The Generator Owner must also cease parallel operation upon notification by the Company of a system emergency, abnormal condition or in cases where such operation is determined to be unsafe, interferes with the supply of service to other customers or interferes with the Company's system maintenance or operation. In addition, the Company may disconnect the generator from the system for system emergencies without notice. However, the Company will use reasonable efforts to notify the Generator Owner prior to disconnecting.
4. *For Routine Maintenance and Repairs* - The Company may disconnect a Customer/Generator Owner for routine maintenance and repairs on the Company's system consistent with applicable Tariffs and agreements. The Company will make reasonable efforts to provide advance notice to the Customer/Generator Owner of service interruptions resulting from routine maintenance. The Company will reconnect the Customer/Generator Owner as quickly as possible following any such service interruption.
5. *Disconnect Means* – The Customer/Generator Owner shall have a disconnect switch within three feet of the meter.

D. Termination

The Generator Owner may terminate the approved Interconnection Application at any time upon thirty (30) days of providing written notice to the Company. The Company may terminate the Interconnection Application for cause after 60 days written notice to the Generator Owner of a material violation of the terms of the approved Interconnection Application and after the Generator Owner has had a reasonable opportunity to remedy the violation. The Generator Owner must give the Company notice that it intends to permanently shut down his generation.

VII. Definitions

Various terms as utilized in this document are defined below. Whenever used in the document with initial capitalization, the following terms have the meanings specified in this Section.

- A. *Account* – An account is one metered or un-metered rate or service classification which normally has one electric delivery point of service. Each account shall have only one electric service supplier providing full electric supply requirements for that account. A premise may have more than one account.
- B. *Company* – Delaware Electric Cooperative (DEC).
- C. *Customer* – Any adult person, partnership, association, corporation, or other entity (i) in whose name a service account is listed, (ii) who occupies or is the ratepayer for a premises, building, structure, etc., and (iii) who is primarily responsible for payment of bills. A Customer includes anyone taking Delivery Service or combined Electric Supply & Delivery Service from the Company under one service classification for one account, premises or site. Multiple premises or sites under the same name are considered multiple Customers.
- D. *Facility (or Facilities)* – The Customer-owned generating equipment and all associated or ancillary equipment, including Interconnection Equipment, on the Customer's side of the Point of Common Coupling (Point of Interconnection).
- E. *Generator Owner* – The owner of the generation Facility that is interconnected to the Company.
- F. *Grid* – The interconnected arrangement of lines, transformers and generators that make up the electric power system.
- G. *Interconnection* – The physical connection of Customer-owned generation to the DEC system in accordance with these technical considerations so that parallel operation can safely occur.
- H. *Interconnection Application* – The standard form of application which must be submitted by the Generation Owner to the Company as a request to interconnect a generating unit to the Delaware Electric Cooperative (DEC) System or to increase the capacity of a generating unit already connected to the DEC system.
- I. *Interconnection Equipment* – That equipment necessary to safely interconnect the Facility to the DEC system, including any and all relaying, interrupting devices, and metering or communication equipment needed to protect the Facility and the DEC system and to control and safely operate the Facility in parallel with the DEC system.
- J. *Interconnection Studies* - Refers to the Feasibility, Impact, and Facilities studies to be performed as applicable and in this order, to determine the generating facility affectation to the DEC system.

- K. *Interface (Isolation) Transformer* – A transformer which interconnects a privately-owned generation source voltage with the DEC system voltage.
- L. *Inverter* – A static power converter with control, protection and filtering functions that converts Direct Current (DC) input to Alternating Current (AC) output. Inverters connected to the DEC system must be of the non-islanding type.
- M. *Island* – A portion of the DEC system containing both load and generation that is electrically isolated from the remainder of the DEC system.
- N. *NEM - Net Energy Metering* – Generation installed to offset a Customer’s energy usage and may occasionally export power to the Grid. Maximum generation size and acceptable fuel source are dictated by the various State jurisdictions.
- O. *NERC - North American Electric Reliability Council*. – The purpose of NERC is to ensure the adequacy, reliability and security of the bulk electric supply systems through coordinated operations and planning of generation and transmission facilities.
- P. *One Way Power Flow* – An interconnected Facility is classified as a “One Way Power Flow” installation if the Facility is configured such that its load is always greater than the generation capacity or the Facility does NOT propose to export excess generated power through the DEC Power Delivery transmission and distribution system. This type of installation will receive power through the DEC interconnection but will never export power back into the DEC Power Delivery transmission and distribution system.
- Q. *Parallel Operation* – Any electrical connection between the DEC system and the Generator Owner’s generation source.
- R. *DEC system* – The electric system of DEC, in whose geographical service area the Customer’s Facility is electrically connected, including transmission and distribution systems.
- S. *PJM - PJM Interconnection, L.L.C.* – PJM Interconnection is a regional transmission organization (RTO) that coordinates the movement of wholesale electricity in all or parts of 13 States and the District of Columbia. Members include electric utilities and independently-owned generating resources. The organization is responsible for dispatching generation, operating the bulk transmission system within its service area and operating a buy/sell market for member’s generation.
- T. *Point of Common Coupling (or PCC)* – The point where the electrical conductors of the DEC system are connected to the Generator Owner’s conductors and where any transfer of electric power between the Generator Owner and the Company takes place. The term Point of Interconnection (POI) used by PJM and other entities is synonymous to Point of Common Coupling.

- U. *Point of Interconnection (POI)* – See definition for “Point of Common Coupling” above.
- V. *Pre-Interconnection Study* – A technical study or studies which may be undertaken by either the Company and/or PJM in response to its receipt of a completed Interconnection Application for Parallel Operation with the DEC system submitted on the Interconnection Application form prescribed by these technical considerations or by PJM. Pre-Interconnection Studies may include, but are not limited to, service studies, coordination studies and facilities impact studies.
- V. *RFC* – ReliabilityFirst Corporation – One of eight Regional Reliability Councils which together form the North American Electric Reliability Council (NERC). RFC is responsible for thirteen States and the District of Columbia including all the DEC service territories in Delaware.
- W. *RTU (Remote Terminal Unit)* – The remote unit of a supervisory control system used to telemeter operating data, provide device status/alarms and to provide remote control of equipment at a substation or generator site. The unit communicates with a master unit at the DEC Control Center.
- X. *Stabilized* – The state of the Company’s system when the voltage and frequency have returned to their normal range for at least 5 minutes or longer following a disturbance after which tripped Customer-owned generation may reconnect to the DEC system. The Company may require a longer time period upon a reasonable showing that reconnection after only 5 minutes will adversely impact the safety and reliability of the DEC system.
- Y. *Stiffness Ratio* – A measure of how strong a generator’s fault current contribution is in comparison to the total fault current available at the Point of Common Coupling.

Stiffness Ratio = Total Fault Current Available at PCC/Generator Fault Contribution
- Z. *System Emergency* – An imminent or occurring condition on the DEC system, the PJM System, the system of a neighboring utility, or in the Facility that is likely to impair system reliability, quality of service, or result in significant disruption of service, or damage, to any of the foregoing, or is likely to endanger life, property or the environment.
- AA. *Two Way Power Flow* – An interconnected Facility is classified as a “Two Way Power Flow” installation if the Facility is configured such that the DEC Power Delivery transmission and distribution system can deliver power to the Generator Owner and the Generator Owner can also export power into the DEC Power Delivery transmission or distribution system. In this type of Facility, the Generator Owner’s load is either variable or smaller than the generating capacity and the Generator Owner proposes to export any excess power.

VIII. Introduction and Purpose

- A. The purpose and intent of this document is to outline the basic requirements to those Customers who are contemplating the installation of privately-owned generation connected to, and operated in parallel with, the DEC system. The information contained in this document is to provide the proposed Generation Owner with a summary of Company and Generator Owner obligations, technical and safety requirements and the need for adequate protective equipment to be designed and installed by the Generator Owner in order to operate one or more generator units in Parallel Operation with the DEC system, without adversely impacting the reliability or power quality of electric service to other Customers or the safety of the general public and Company employees. The information contained in this document should be useful in understanding the need for a proper design and the details needed to complete a comprehensive interconnection feasibility study.
- B. No one document can provide all the details needed to cover every conceivable generator installation. Consequently, this document is provided only as a starting point and a source of preliminary information. Any Customer considering the installation of interconnected generation will have to consult all available resources, design standards and professionals necessary to develop a feasible design and installation.

IX. Generator Owner Obligations

In the course of owning, interconnecting and operating a generator in parallel with the DEC system, the Generator Owner is responsible for the following obligations:

- A. The Generator Owner must design and construct their Facility to meet all applicable national, state and local construction and safety codes.
- B. The Generator Owner must design their Facility with protective hardware and software to prevent the generator from energizing any Company de-energized circuit.
- C. The Generator Owner must design their Facility with protective hardware and software to automatically disconnect from the Company Grid if the source from the DEC system is lost, irrespective of connected loads or other generators on the circuit. Operating an intentional island of Customer-owned generation with other Customers will be permitted only if specific contractual arrangements have been made and necessary equipment has been installed and confirmed by the Generator Owner that the equipment will satisfactorily control and stabilize voltage and frequency within the island.
- D. The Generator Owner must equip his Facility with the necessary protective hardware and software designed to prevent sustained Parallel Operation of the generator with the DEC system unless the system service voltage and frequency are within acceptable magnitudes as defined in Section VIII, B and C.

- E. The Generator Owner is responsible for protecting his own Facility in such a manner that Company Grid outages, short circuits, single phasing conditions or other disturbances including zero sequence currents and ferroresonant over voltages do not damage the Generator Owner's equipment.
- F. The Generator Owner is responsible for protecting his generator and equipment from the effects of switching or automatic reclosing on the DEC system circuit(s) supplying the Generator Owner's Facility.
- G. The Generator Owner shall insure that his designs utilize equipment properly sized to meet the operating voltage, current rating, fault duty, etc. necessary for the site.
- H. The Generator Owner is responsible for protecting its own generator and all interconnection / ancillary equipment. The Generator Owner must supply the required protection schemes along with the necessary metering and monitor/control requirements specified either by DEC Power Delivery or by PJM.
- I. The design, procurement, installation and maintenance of all equipment at the Generator Owner's Facility are the responsibility of the Generator Owner. The Generator Owner is responsible for all costs.
- J. The Generator Owner will supply the Company with the necessary technical information, one-lines, equipment data, specifications, etc. so that so that the Company can conduct a complete review of the proposed Facility and conduct any necessary studies. (See Appendix B)
- K. The Generator Owner will cover the expense of any Company Service Study, Coordination Study or Facility Impact Study necessary to assess the impact of the interconnected generation. The scope of such Pre-Interconnection Studies will be based on the generator characteristics and the location of the proposed Point of Common Coupling. (The expense shall be directly reimbursed to the Company or through PJM.)
- L. Any necessary enhancements or improvements needed within the DEC system, neighboring utility system and/or at other Customer sites to accommodate the Parallel Operation of the Generator Owner's generator will be at the Generation Owner's cost, unless otherwise allocated in accordance with PJM Transmission Tariff, the PJM Operating Agreement or State regulation.
- M. The Generator Owner has full responsibility and liability for the safe and proper operation and control of their equipment and for the power originating from their generator.
- N. The Generator Owner is responsible for synchronizing their generator to the DEC system and maintaining a synchronous condition.

- O. The Generator Owner shall maintain their Facility in good working order, consistent with industry standards, manufacturer recommendations, and in compliance with all applicable rules, codes and regulations. The Generation Owner shall have a maintenance and testing program that ensures all protective schemes and equipment are periodically calibrated and functionally tested. *PJM Relay Testing and Maintenance Practices* shall be followed for all facilities participating in the PJM marketplace, or interconnected at 138 kV and above. The Company may periodically request supporting documentation that confirms the Generator Owner's maintenance and testing program.
- P. The Generator Owner must immediately cease parallel operation upon notification by the Company that their operation is unsafe, interferes with the quality of supply to other Customers or interferes with the Company's system maintenance or operation.
- Q. The Generator Owner will connect and disconnect their generator to/from the DEC system only under the direction and approval of DEC. (NEM generators and other generators 25 kW or less are generally exempt from this requirement.)
- R. The Generator Owner will obtain and cover the cost of any required communication circuits to their site for protective relaying, generator monitoring/control, metering and equipment remote access.
- S. The generator must not be connected in parallel with the DEC system until the Company has granted approval to interconnect and the Generator Owner has received such notification.
- T. The Generator Owner will apply a Warning Label provided by the Company in a conspicuous place on or near their meter, meter box, breaker or Point of Common Coupling to notify Company personnel that there is a generator source at the site.
- U. The Generator Owner must notify the Company in writing if it intends to add or modify any equipment at its Facility that impacts the protection associated with the Point of Common Coupling. The Generator Owner must also give the Company reasonable advance notice if it intends to permanently shut down their generation.
- V. The Generator Owner shall maintain an operating log at their Facility which details all changes in operating status, trip occurrences, maintenance outages or other unusual conditions found upon inspection. The Company may require other information to be logged. The Generator Owner and the Company will generally negotiate the specific information that must be logged at each site. The operating log shall be available to the Company upon request and shall be maintained by the Generator Owner at their Facility.

- W. The Generator Owner must accept the fact that all Customers including Generator Owners may be switched temporarily or permanently from one DEC system substation or circuit to another in response to such causes as load growth, equipment failure, maintenance outages or other reason deemed prudent by DEC. The Generator Owner is responsible for any redesign or setting adjustments in their Facility that are necessary to accommodate a permanent or temporary transfer to another DEC substation or circuit.
- X. The Generator Owner will most likely not be allowed to operate when temporarily transferred to another Company circuit or for other abnormal circuit conditions. This is particularly true if the protection of the normal source circuit has been modified to specifically accommodate the generator interconnection. When requested by the Company, the Generator Owner must cease parallel operation of their generation and reconnect their generation only when permission has been received from the Company.

X. DEC Power Delivery Obligations

In negotiation, in reviewing an Interconnection Application and in ongoing operation with a Generator Owner, the Company is responsible for the following obligations:

- A. The Company will provide the Generator Owner with the DEC system available fault current, system impedance and protection system details at the proposed Point of Common Coupling. This data will be updated, as required, when significant system changes occur.
- B. The Company will review the proposed Facility design and make all the necessary Pre- Interconnection Studies to evaluate the impact of the generator on the DEC system and to identify any enhancements necessary. The Company should complete this review in a timely manner and within the timeframe that may be required by State regulation.
- C. The Company will review and provide feedback to the Generator Owner on the proposed design and protection schemes associated with the Point of Common Coupling. The Company may also review and provide comment on the generator protection and protective relay settings. However, any review by the Company does not relieve the Generation Owner of full responsibility for the protection of their generator and equipment.
- D. The Company will provide the Generation Owner with the technical details and requirements necessary to satisfy the generator metering and RTU monitoring/control needs for each specific generator installation site.
- E. The Company will provide written approval or enter into an appropriate agreement for the interconnection of the Generator Owner's Facility as soon as all requirements are satisfied. Such approval does not, however, supersede the Generator Owner's obligations or imply that the Facility meets all federal, state and local standards. If not approved, the Company will provide details on the reason or reasons for denying the parallel interconnection.

- F. The Company, in the course of reviewing applications for interconnected parallel generators and making any necessary Pre-Interconnection Studies, has the need for detailed information on the proposed Generator Owner's Facility. The Company or any of its affiliates shall not use such knowledge and information submitted by the proposed Generator Owner to offer competing services or special rate considerations. In addition, the Company will not divulge this information to a third party without the Generator Owner's consent.
- G. The Company may disconnect and isolate the Generator Owner's Facility from the DEC system for routine maintenance and repairs on the Company's Grid consistent with applicable Tariffs and agreements. The Company will make reasonable efforts to provide advance notice to the Generator Owner of service interruptions resulting from routine maintenance. The Company will reconnect the Generator Owner's Facility as quickly as possible following any such service interruption.
- H. The Company reserves the right to disconnect and isolate the Generator Owner's Facility from the DEC system for system emergencies or unsafe conditions without notice. The Company will use reasonable efforts to notify the Generator Owner prior to disconnecting.
- I. The Company will advise the Generator Owner with as much lead time as possible when the Generator Owner's Facility must be transferred from one DEC system circuit to another circuit. The Company will also advise the Generator Owner of data on the new DEC system circuit needed by the Generator Owner to re-design or reset equipment at their Facility.

XI. Technical Design Considerations

A. General

1. This Technical Considerations Document describes the minimum design requirements and operating procedures necessary for the safe and effective interconnection of parallel Customer-owned generation. The Generator Owner's design must meet or exceed the requirements outlined in these Technical Considerations and also meet any applicable Tariff requirements. Some aspects of the Generator Owner's design and operation must meet PJM, IEEE, RFC and NERC standards and requirements. These standards and requirements are routinely modified. This document attempts to enumerate the standards and requirements in effect at the time of writing. Company approval of the Generator Owner's design does not relieve the Generator Owner's responsibility to comply with all standards and requirements whether listed herein or not. It is the Generator Owner's responsibility to know and understand all applicable requirements.
2. The Generator Owner's Facility must meet all applicable national, state and local municipal construction, safety and electrical codes. Company approval to interconnect indicates only that the minimum requirements for parallel operation outlined in this document have been satisfied. Such approval does not imply that the Generator Owner's Facility meets all federal, state and local standards and regulations.

3. All equipment, circuit breakers and other current interrupting devices at the Generator Owner's Facility must be capable of interrupting the maximum available fault current at the site including any contribution from the Facility's generator.
4. The Generator Owner must furnish and install a manual disconnect device which, when opened, will have the effect of isolating the generator from the DEC system. This disconnect device shall have a visual break such as a disconnect switch, a draw-out breaker, fuse block, etc. as appropriate to the voltage level. The disconnect device will, at all times, be accessible to Company personnel and be capable of being locked in the open position via a Company padlock.

Note: The Company will use reasonable efforts to utilize padlocks of a size consistent with typical manufacturer's specifications.) For interconnection voltages of 480 volts or less, the disconnection means shall be within three feet of the meter.

B. Background Information and Need for Protection

1. The DEC system is subject to a variety of natural and man-made hazards. Among these are lightning, wind, snow, animals, vehicular-pole accidents, vandalism and human error. These same hazards are present in residential and commercial electric systems but to a lesser degree due to the smaller size and protected environment of these systems.
2. The electric problems that can result from the preceding hazards are principally short circuits, grounded conductors and broken or open conductors. All of these problems require that the affected equipment be de-energized as quickly as possible to minimize equipment damage, to protect Grid security, to lessen the adverse impact on Customers and to remove any hazard to the public and Company personnel.
3. When Customer-owned generators are connected to and operate in parallel with the Grid, the Generator Owner has the responsibility to protect both his own Facility and the Grid from the impact of his Facility.

C. Basic Protection Goals

The protection system at the Point of Common Coupling should be designed and operated with the following desired goals in mind:

1. Protect the DEC system from the adverse impacts of the parallel generator and from faults within the Customer's Facility.
2. Protect the parallel generator from faults or other disturbances in the DEC system.
3. Disconnect the parallel generator from the DEC system for abnormal operating conditions.
4. Permit the desired range of power transfer without false operation.

D. Protection General Requirements

The generator and Point of Common Coupling protection schemes shall be continuously monitored and in a functional state. The generator shall immediately be disconnected from the Company Grid for any condition that would make the protection scheme inoperable.

1. The operating power for the generator and Point of Common Coupling protection schemes and the control power used to disconnect the generator from the Company Grid must not be dependent on Company Grid power.
2. The generator protection shall be designed to automatically and immediately disconnect the generator from the DEC system if the source circuit from the Company is lost, irrespective of connected loads or other generators on the circuit.
3. The generator shall be equipped with protective equipment (hardware or software) to prevent the generator from energizing a de-energized DEC system circuit.
4. Parallel operation must cease immediately and automatically for abnormal operating voltage, frequency, harmonic content or power flow. Parallel operation must also cease for loss of a phase or improper phase sequence. Voltage sensing shall be performed on all three phases.
5. Protection at the Point of Common Coupling must detect and isolate the Facility from the DEC system for a fault condition in the Generation Owner's Facility.
6. Protection at the Point of Common Coupling must detect and isolate from the Company Grid the Generation Owner's Facility for a fault condition on the DEC system circuit that supplies the Customer generator site.
7. The protection scheme should permit the desired range of power transfer without false operation. The protection scheme should also prevent excessive or unnecessary tripping that would adversely affect the Company's service reliability to other Customers or Generator Owners.
8. The generator protection or protection at the Point of Common Coupling must insure that the generator is disconnected from the Company Grid before any automatic re-energizing of the DEC system supply circuit.
9. The protection at the Point of Common Coupling must recognize and disconnect the Generator from the Company Grid before entering Island mode. Generators that serve only the specific customer load must have necessary equipment to insure no power will be exported to the DEC system during an outage of the DEC system whether planned or during an emergency. Any automatic reconnection of the generator to the Grid following a loss and subsequent restoration of the DEC system source must occur only after the Company Grid has stabilized.

Note:

1. This preceding list of design requirements is not intended to be all-inclusive. Other hazards and conditions may need to be taken into consideration by the design engineer based upon the circumstances, the specific site, the Generation Owner’s needs and other appropriate criteria.

E. Grid Interconnection Point Information

Generator Owner will normally want to interconnect their generator to a DEC system circuit or power substation that is near their site. Some details on the Company Grid are noted below to assist the Generator Owner in the design of their Facility.

1. The DEC system distribution facilities consist of voltages shown in the following:

Table 1, DEC Distribution Facility Voltages

Voltage	DEC-Owned Lines
12,470/7,200	Three-Phase, Single Source
277/480	Three-Phase, Grounded Wye
120/208	Three-Phase, Grounded Wye
120/240	Single-Phase

2. The DEC system transmission facilities consist of 69 kV and 138 kV circuits.
3. Not all delivery voltages are available at any particular location. The Company must be contacted regarding the availability of specific delivery voltages for interconnection at a particular site.
4. The DEC system can only accept 60 Hz alternating current from parallel generators. All AC generators within the size range covered by this document must be three-phase unless approved by DEC.
5. The Company may limit the size of the generator that can be interconnected at any particular location due to the existing infrastructure and loading of the Grid surrounding the proposed generator site. The presence of existing interconnected generators on the circuit may also limit the size of any new proposed generator interconnection. Any Company Grid upgrades or new construction necessary to interconnect a generator larger than the existing Grid will support will be done at the Generator Owner’s expense, unless otherwise allocated in accordance with PJM Tariff, PJM Operating Agreement or State regulation.
6. The following table provides typical maximum generator size in MW that can generally be interconnected at the various DEC system voltage levels. Existing installed generation may further limit the size of additional generation that can be added.

Table 2, Typical Maximum Size Generation in MW

Voltage Level	12.47 kV	69 kV	138 kV
Maximum Typical Generation Size Allowed on Non-Express Circuits	2.0	Note 2	Note 2
Maximum Typical Generation Size Allowed on Express Circuits (Note 1)	5.0	Note 2	Note 2

Notes:

- a) Express Circuits are new dedicated facilities specifically constructed to interconnect the Generator Owner facilities with the DEC system. The need for an Express Circuit will be based on the results of the Pre-Interconnection Study.
 - b) The results of the PJM Interconnection Study or the DEC Interconnection Study will determine on a case by case basis the maximum generation that can be interconnected at these transmission voltages.
7. Most distribution and transmission lines have automatic line restoration following a line trip. The majority of faults (short circuits) are temporary in nature such as a flashed insulator or a tree limb that brushed against a line. Once the fault has been detected and the affected circuit de-energized, the circuit can normally be successfully re-energized. This re-energizing or automatic reclose could occur after the line has been dead for 0.20 second, up to a minute or more. The net result of automatic line restoration is to restore the integrity of the Grid and to minimize any Customer outage time. The Generator Owner will have to take into account the impact of automatic circuit restoration in the design and operation of their Facility. See Section VIII, D, E, and F.
 8. The Generator Owner may request the Company to delay any high speed reclosing on the DEC system supply circuit to allow the Parallel Operation generator sufficient time to remove itself from an islanded or de-energized circuit prior to automatic reclose. Since delaying the automatic reclose time degrades the level of service to other Customers on the circuit, the Company may limit any delay of the automatic reclose to a few seconds, or less. A direct transfer trip scheme is often needed to disconnect the interconnected generator prior to automatic reclosing. The transfer trip scheme will utilize a communication channel between the Company Facility and Generator Owner's site. A synchronizing check or reclose-blocking scheme may need to be installed on the Company's source circuit to prevent out-of-phase reclosing. The Generator Owner is responsible for all costs associated with the installation and maintenance of improvements necessary for the generator interconnection.
 9. Generators connected to a distribution circuit will require an Automatic Line Recloser (ALR) or Circuit Breaker with appropriate protective relaying be installed at the Point of Common Coupling owned by DEC and paid for by the Generation Owner. DEC may require a second ALR or circuit breaker at the Customer's transformer on the distribution voltage side if Customer's transformer is over 100 feet from the Point of Common Coupling.

F. Interface (Isolation) Transformer

1. In most cases, an Interface (Isolation) Transformer will be required to interconnect the Generation Owner's Facility to the DEC system voltage. This Interface (Isolation) Transformer will decrease possible voltage variations seen by other Company Customers, attenuate any possible harmonics and reduce the effects of fault currents.
2. The Company reserves the right to specify the type of Interface (Isolation) Transformer connection (e.g. delta-delta, wye-delta, wye-wye, and delta-wye) that should be utilized, consistent, where reasonable, with the needs of the Generator Owner's Facility. The intent here is to best integrate the transformer with the circuit grounding and area ground fault detection schemes.
3. For all generation connected to the DEC system, the Interface (Isolation) transformer shall have a grounded wye connection to the DEC system.
4. An Interface (Isolation) Transformer that interfaces to the Company Grid with an ungrounded connection (delta or ungrounded wye) requires a special protection scheme to detect a grounded high side conductor. (See Protection Scheme Details, Section X - F, Table 4)
5. The Interface (Isolation) Transformer must be sized to support maximum anticipated power transfers to and from the Company Grid.

G. Power Quality Considerations

1. The Generator Owner's Facility shall be designed and operated in such a manner that there are no noticeable adverse impacts to system voltage, frequency, harmonics, etc.
2. The parallel generation shall not cause excessive voltage flicker on the DEC system. (Voltage flicker is defined as variations in system voltage magnitude and with duration sufficient to allow visual observation of a change in electric light source intensity.) Any flicker shall not exceed the "Borderline of Irritation" Curve, Figure 1, as defined in IEEE Std. 1453-2015, *Recommended Practice for the Analysis of Fluctuating Installations on Power Systems*. The Company reserves the right to require tighter flicker control in situations where other Customer's or the Company's equipment or operations (computers, instrumentation, process controls, etc.) are impacted.
3. The parallel generation could introduce harmonics distortion into the Company Grid if equipment such as DC to AC inverters are used in the Facility. (Harmonic distortion is defined as continuous distortion of the normal 60 Hz. sine wave typically caused by non-linear loads or by inverters, measured in total harmonic distortion, THD.) Any voltage harmonic distortion shall not exceed the limitation as defined in IEEE Std. 519-2014, *Recommended Practices and Requirements for Harmonic Control in Electric Power Systems*, Table 1. The limits vary dependent on the voltage. In addition, the level of harmonic current that the Generator Owner shall inject into the Company Grid should not exceed the level specified in Tables 2 and 3 in IEEE Std. 519-2014.

4. Any DC to AC inverter should not inject DC current greater than 0.5% of the rated inverter capacity into the Point of Common Coupling during both normal and abnormal operation.

H. Power Quality Considerations

1. For Customer-owned generators seeking parallel operation through an Interconnection Request directly to PJM, the generator(s) must adhere to the power factor requirements as detailed in PJM Manual 14A, *Generation and Transmission Interconnection Process*, Section 5: *Additional Generator Requirements* and the PJM Tariff at Attachment O, Appendix 2, Section 4.7. Otherwise, the power factor requirements listed below apply.
2. A parallel generator shall not adversely impact the power factor of the DEC system. The type of generator impacts the power factor. The inverters of most DC generators are designed to operate close to unity power factor unless otherwise configured. Induction generators absorb VARs from the DEC system. Synchronous generators can either absorb or produce VARs thus having a varying power factor depending upon excitation control.
3. Synchronous generators shall have and maintain a minimum design capacity to operate at a power factor between 0.85 to 1.0 lagging, i.e. supplying VARs to the DEC system.
4. If the generation interconnection is not in PJM queue, synchronous generators shall generally be operated so as not to absorb VARs from the DEC system unless directed by DEC. If the generation interconnection is in PJM queue, PJM rules will apply as noted above in line 1) of this Section.
5. The dispatching authority (PJM or DEC) can request that the generator real and reactive power output be adjusted to best meet the needs of the overall Grid.
6. Depending on the Point of Common Coupling location, the DEC system can be limited in the amount of reactive power capacity available to the Generator Owner. The Generator Owner must provide for his own reactive power requirements (via generator control, capacitors, etc.) so as to operate at no less a power factor (drawing VARs from the DEC system) at the Point of Common Coupling than existed prior to the installation of the Facility. Any reactive power requirements in excess of this limit may require upgrades and/or the installation of capacitor units on the DEC system. The costs for any such upgrades will be charged to the Generator Owner. Specific purchase power arrangements, including power factor requirements, are defined in appropriate Tariffs and Interconnection Agreements.
7. It is the Generator Owner's responsibility to provide adequate mitigation equipment or controls to insure that any variation in voltage at the Point of Common Coupling does not exceed the limits defined in the Tariff and by the local regulatory jurisdiction. When the generator is connected to distribution circuits at 12 kV or below, the generator voltage regulation must be set to properly coordinate with voltage regulating equipment on the DEC Power Delivery circuit.

8. For intermittent type generators such as wind and solar (photovoltaic) the generator may be required to operate in a fixed absorbing VARs power factor schedule to mitigate voltage impacts caused by power output fluctuations. If the generating Facility is capable and obtains permission from DEC, it may operate in a dynamic mode to mitigate voltage impacts by dynamically controlling VARs.

I. Inverter Considerations

Photovoltaic, fuel cell and wind DC generation sources will utilize inverters to convert their DC output to AC power acceptable to the Grid.

1. The Generator Owner must use a non-islanding type inverter. If the grid loses power for any reason, the generation source must either disconnect from the grid or cease operation.
2. Non-islanding type inverters are inherently designed to automatically disconnect from the Grid if the Generator Owner's site becomes isolated from the DEC system. This type inverter also prevents the Generator owner from inadvertently supplying other Company Customers in an isolated Island situation.
3. The inverter output specifications must meet the power quality considerations detailed in Section VII, H. Inverters used in energy farm-type installations may need to include dynamic VAR compensation or use other mitigating means to maintain voltage regulation at the Power of Common Coupling. Dynamic inverters that do not meet the anti-islanding provisions will generally require transfer trip from the upstream protective device(s).

J. Induction Generator Considerations

Wind and other generation sources utilizing induction generators, singularly or in aggregate, could fall within the lower range of parallel generator sizes covered by this Technical Consideration document.

1. The reactive supply for induction generators may impose some design and generator size constraints because these generators obtain their excitation from the Grid. Capacitors may have to be added either at the Generator Owner's site or on the DEC system. (See Section VIII, H) The addition of capacitors may also cause undesirable ferro resonance. The cost to install and maintain capacitors on the DEC system specifically for the generator is the Generator Owner's responsibility.
2. Any flicker produced in the course of starting an induction generator and bringing it up to synchronous speed (as an induction motor) must not exceed the flicker limit detailed in Section XI, D, 3).
3. The installation of capacitors for reactive supply at or near an induction generator site greatly increases the risk that the induction machine may become self-excited if somehow isolated from the Grid. A self-excited induction generator can rapidly produce abnormally high voltages which can damage equipment on the Grid and at other Customer sites. Self-excitation is more likely

where the Grid capacity and the circuit load density are both low.

4. The Generator Owner with an induction generator must include protection at their Facility to detect self-excitation operation and disconnect the generator from the DEC system.
5. By their design, induction generators can only supply fault current for a short period of time as the field flux decays rapidly on removal or decay of the source voltage.

K. Synchronous Generator Considerations

1. By their design and generally larger size, synchronous generators are capable of supporting sustained fault currents. As such, the protection scheme associated with the Point of Common Coupling must be designed to insure detection of fault conditions in the DEC system.
2. Synchronous generators are capable of operating independently irrespective of the Grid source. They can continue to operate after being isolated from the Grid providing the load is within the generator's capacity. Consequently, a more robust protection scheme is generally needed to detect isolation from the Grid. Transfer trip from the Company is generally required.
3. Sufficient generator reactive power control capability shall be provided to withstand normal voltage changes on the DEC system.

L. Interval (Revenue) Metering Considerations

For Customer-owned generators seeking parallel operation through an Interconnection Request directly to PJM, generator(s) must adhere to the metering requirements as outlined in PJM Manual 01, *Control Center and Data Exchange Requirements*, Section 5: *Metering Requirements* and PJM Tariff, Attachment O, Appendix 2, Section 8. Additional DEC metering requirements are detailed below and also apply to PJM queue projects, except as noted.

The requirements for each parallel generator installation will be reviewed and revised on a case-by- case basis. Listed below are the standard requirements for generator Interval Metering. The Company, however, reserves the right to specify the required interval metering equipment for each paralleled generator site.

1. All paralleled generator Facilities shall be metered in accordance with applicable Tariffs and specifications provided in approved Company publications. (Does not apply to PJM generation queue projects.)
2. An Interval (Revenue) Meter must be located at each Point of Common Coupling. The Interval Meter will record MWh and MVarh input and output.
3. The Generator Owner may net retail site load behind a single meter at the Point of Common Coupling except:

- a) A separate Interval Meter is required for each generator if the generator or aggregate generation is greater than 2 MW.
 - b) In cases where the generation is served under a generator “Standby Tariff”. Under this Tariff, each generator must have a separate Interval Meter to record MWh and MVarh input and output. (Note: Does not apply to PJM queue projects.)
4. Generator site auxiliary loads that are not measured by the generator Interval Meter will require a separate meter.
 5. The Generator Owner shall supply a telephone line for the Interval Meter data recorder which allows the Company to dial-up and retrieve the Interval Meter data remotely. Specific requirements will be determined on a case-by-case basis.
 6. Unless otherwise mutually agreed upon by the Company and Generator Owner, the Company shall install and own all Interval Metering equipment at the Point of Common Coupling and on the generator(s). The Generator Owner shall pay the Company the initial costs to procure, install, test and startup the metering and associated related equipment. Thereafter, the metering equipment shall be owned, operated and maintained by the Company. (These provisions are subject to possible modification by PJM, regulatory commissions or applicable Tariffs. PJM allows Generator Owners to install, own, operate and maintain the Interval Metering (i.e. PJM “Metering Equipment”)) The Company and the Generator Owner may agree to have the Generator Owner install the metering PTs (potential transformers) and CTs (current transformers) within the Generator Owner’s switchgear equipment.
 7. All metering shall comply with ANSI and Company technical requirements (including meter model, options and programming). The Point of Common Coupling and generator Interval Meters shall be bi-directional so that power deliveries (including reactive) to and from the Generator Owner’s site can be separately recorded. The Point of Common Coupling Interval Meter shall be equipped with detents to prevent reverse registration.
 8. The Generator Owner may, at its sole option and cost, install or have the Company install additional metering equipment to meet any special needs that the Generator Owner may have.

M. Monitoring, Control and Remote Telecommunication Considerations

For Customer-owned generators seeking parallel operation through an Interconnection Request directly to PJM, the generator(s) must adhere to the monitoring, control and remote telecommunication requirements as outlined in PJM Manual 01, *Control Center and Data Exchange Requirements* and PJM Manual 14D, *Generator Operational Requirements*. Additional DEC monitoring, control and telecommunication requirements are detailed below and also apply to PJM queue projects, except as noted.

Since parallel generators, particularly the larger units, have a direct impact on the overall operation and performance of the Grid, it is important that the Company monitor and have emergency trip control of the generator interface breaker(s). The requirements for each parallel generator installation will be reviewed on a case-by-case basis.

1. Telemetered data for each meter required in preceding Section X, D shall be telemetered to DEC's designated Control Center via a dedicated data circuit (see line 3 below for an exception).
2. The Generator Owner shall purchase and install a Remote Terminal Unit (RTU) of a DEC approved vendor to enable the Company and, if required, PJM to monitor the status of the data points at the Generator Owner's site and to control certain breakers, if required. This RTU shall utilize DNP 3.0 protocol, or other such protocol compatible with the existing Supervisory Control System at the

Company. Required data points are listed in M.6 below. In addition, the Generator shall supply a data link for transmitting the telemetry data between the Generator Owner's RTU and the appropriate DEC Control Center.
3. A generator or aggregate generation of 10 MW, or less, behind a Point of Common Coupling that is exporting energy and/or capacity to PJM may send telemetry data for the Point of Common Coupling and generator meters to PJM via an internet option in lieu of sending telemetry directly to DEC. The Generator Owner must authorize PJM to resend the telemetry data to DEC. DEC may still require direct telemetry under special circumstances. The required data points are listed in M.6 below. PJM should be contacted for detailed information on the internet option.
4. Specific data points will vary depending upon on the size of the interconnected generation. Analog telemetry and status indication points are listed below in M.6. In addition, certain control functions may be required to allow remote dispatch of generation or for isolating the generation from the DEC system in the event of a system emergency. Specific monitoring and control requirements will be determined on a case-by-case basis.
5. Remote tripping capability by DEC system Operations is required for all generator interconnections larger than 2 MW or interconnected at 12.47 kV or higher voltage, as noted below in line 6.
6. Telemetry and control requirements by generator capacity:
 - a. Units 25 kW to 2 MW Capacity
 - 1) Generation MW and MVar Output, MWh and MVarh for each generator if Standby Tariff applies.

b. Units Greater Than 2 MW to 10 MW Capacity

- 1) Point of Common Coupling MW, MVar, MWh, MVarh, Amp Flow on each Point of Common Coupling.
- 2) Generation Bus and Point of Common Coupling Bus Voltages.
- 3) Status indication of generator breaker(s) and Point of Common Coupling breaker/ switch.
- 4) Remote generator breaker tripping capability by DEC system Operations.
- 5) Generation MW and MVar Output, MWh and MVarh for each generator, if the Standby Tariff applies.

The Generator Owner's RTU shall connect directly to DEC. For PJM projects, the required telemetry data may be retransmitted to DEC. If data is retransmitted by PJM, the Generator Owner shall grant PJM permission to retransmit the data to DEC.

c. Units Greater Than 10 MW to 50 MW Capacity

- 1) MW and MVar Output, MWh and MVarh for each generator.
- 2) MW, MVar, Amp Flow, MWh and MVarh on each Point of Common Coupling.
- 3) Generation Bus and Point of Common Coupling Bus Voltages.
- 4) Frequency at the Point of Common Coupling.
- 5) Status indication of generator breaker(s) and Point of Common Coupling breaker.
- 6) Remote generator breaker tripping capability by DEC system Operations. The Generator Owner's RTU shall connect directly to DEC.

d. Units Greater Than 50 MW

- 1) MW and MVar Output, MWh and Mvarh for each generator.
- 2) MW and MVar load of generator auxiliaries and Facility.
- 3) MW, MVar, Amp Flow, MWh and Mvarh on each Point of Common Coupling.
- 4) MW, MVar, Amp Flow through the Interface Transformer if site loading causes the flow through the Interface Transformer to be different than the generator.

- 5) Generation Bus and Point of Common Coupling Bus Voltages
- 6) Frequency at the Point of Common Coupling.
- 7) Status indication of generator breakers and all substation breakers.
- 8) Remote generator breaker tripping capability by DEC system Operations. The Generator Owner's RTU shall connect directly to DEC.

Notes:

1. The Generator Owner shall contact PJM directly and review PJM documents to insure compliance with all the PJM RTU monitoring/control requirements for their proposed site.
2. The Company will allow multiple generator unit data to be combined into a single unit for Facilities not exceeding 10 MW total for all units.

N. Event Recording Considerations

1. The Generator Owner shall purchase and install recording equipment to monitor the performance of their protection and control equipment for those parallel generator sites interconnected with the DEC system at a voltages level of 69 kV and above.
2. The Company reserves the right to specify the voltages, currents, device status, etc. to be monitored and recorded by this event recording equipment.
3. Event information may be recorded by event record features internal to microprocessor type protective relays, by separate digital fault/event recorders or by a combination of these two methods.
4. When a digital fault/event recorder is installed, the Company will specify a manufacturer and type to insure compatibility with other digital fault/event recorders in the DEC system.
5. The Company shall have remote access to any recorded information for use in analyzing the performance of the overall electric Grid.
6. The Generator Owner will supply a dialup telephone line for the event recording equipment for remote access of the data.
7. The prospective Generator Owner should comply with NERC Standard PRC-002-2 *Disturbance Monitoring and Reporting Requirements*. NERC Standards are routinely modified. It is the responsibility of Generator Owner to be knowledgeable of an in compliance with applicable NERC Standards.
8. Digital fault recorders should be time synchronized to a reference traceable to the National Institute of Standards and Technology (NIST)

XII. Performance Considerations

A. General

1. The interconnection of parallel generation with the DEC system is permissible only if the system voltage, frequency and current flow at the Point of Common Coupling are within normal limits. Parallel operation must cease immediately and automatically for abnormal voltage, frequency, or current flow as defined below.
2. Parallel operation must also cease automatically for operation outside the power quality limitations detailed in Technical Design Considerations, Section X, G.

B. Voltage Limits

1. The Generator Owner's equipment shall be operated in such a manner that the voltage levels on the Company's Grid remain within the operating limits defined by ANSI C84.1-2016 and within the limits defined by Tariff and local regulatory jurisdiction.
2. The generator must immediately and automatically cease parallel operation and disconnect from the DEC system if the voltage at the Point of Common Coupling exceeds the limits defined following:

Notes:

- a) Trip time refers to the time between when the abnormal voltage condition occurs, and the generator being disconnected from the Company Grid.
 - b) Three-phase voltage sensing shall be used.
 - c) The voltages must be sensed on the high side of any Interface (Isolation) Transformer if the high voltage winding is ungrounded. Such a scheme is necessary to rapidly detect severe over voltages that occur for a grounded high side conductor being energized from an ungrounded generation source. These high voltages can quickly cause catastrophic failure of lightning arresters and lead to other equipment insulation failures.
 - d) Exceptions to these limits may be granted or required for bulk synchronous generators with a contractual obligation and authority to supply other Customer load in an Island mode arrangement. These generators must install appropriate equipment to control and stabilize voltage within the Island.
3. The Generator Owner may reconnect to the Grid when the system voltage returns to normal range and the Grid is stabilized. Reconnection approval shall be requested from the Company Control Center. NEM generators and other generators 2 MW or less are generally exempt from receiving reconnection approval.

C. Frequency Limits

1. The generator must immediately and automatically cease parallel operation and disconnect from the DEC system if the operating frequency exceeds the limits defined below.

Notes:

- a) Trip time refers to the time between when the abnormal frequency condition occurs, and the generator being disconnected from the Company Grid.
 - b) Synchronous Generators less than 20 MW whose output is netted with peak load (net system load reducer) to calculate PJM under frequency load shedding needs, will also have to meet frequency requirements for PJM Market generators.
 - c) PJM Frequency requirements are to provide uniformity across the entire Grid and to insure that all generator units will remain online until the frequency limits are reached.
 - d) PJM can grant an exception to the trip frequency requirement if warranted.
2. The Generator Owner may reconnect to the Grid when the system frequency returns to normal range and the Grid is stabilized. Reconnection approval shall be requested from the Company Control Center. NEM generators and other generators 2 MW, or less, are generally exempt from receiving reconnection approval.

D. Synchronization

1. In order to avoid damaging a generator during synchronizing, the generator manufacturer will generally provide synchronizing limits in terms of breaker closing angle, slip frequency and voltage matching. Those manufacturer limits should be followed but in no case should they exceed the limits listed below.

Table 3, Synchronization Limits

Frequency Difference (Slip)	Voltage Difference	Phase Angle Difference
0.2 Hz.	10%	10 Degrees

2. Generators with a Stiffness Ratio of 20, or less, or units where a stability study has indicated possible unstable operation shall be equipped with a protective functions suitable for detecting loss of synchronism (out of step or pole slipping).
3. Induction generators that are started across the line shall not cause voltage flicker to exceed the limitation defined in Technical Design Considerations, Section X, H, 2. If these flicker limits are exceeded, the induction generator shall be accelerated to synchronous speed by the prime mover prior to paralleling with the Company Grid.

4. The inverters of DC generating systems shall obtain their commutation reference from the Company Grid and thus synchronization will not be an issue.

E. Island Operation

1. The generator must automatically and immediately disconnect from the DEC system if the source from the Grid is lost. This separation must occur irrespective of connected load or other generators on the circuit.
2. The generator must be disconnected from the Company Grid before any automatic reclose or reenergizing of the Company source.
3. Operating an intentional Island using Customer-owned generation will be permitted only if serving the specific load of the generator owner and the necessary equipment has been installed by the Generator Owner to insure no power is exported to DEC's System.
4. Reconnecting the Island to the Company Grid must be done at a tie location with facilities for synchronizing the Islanded generation to the Grid. Otherwise, the Island generation must be disconnected before the tie is made to the Grid.

F. Fault Detection and Isolation

1. The Generator Owner must have protective relaying to detect a fault condition on the Company source circuit that interconnects with the Generator Owner's Facility. The protective relaying must detect the Company circuit fault and disconnect the generator from the Grid. The required operating time of the protection scheme is dependent on many variables such as voltage class, generator stability concerns, primary versus backup relaying, coordination requirements with Company relaying scheme, etc. The Company will work with the Generator Owner and ascertain the performance requirements on a case by case basis.
2. In cases where clearing time from the Generator Site is critical and/or when a high speed auto reclose is needed on the source circuit, transfer trip from the Company end of the circuit to the Generator Owner's site will be required.
3. For a fault condition within the Generator Owner's Facility, the Generator Owner must have protective relaying to detect and isolate the fault from the DEC system. The required clearing time of the Facility's protection schemes is dependent on many variables such as voltage class and the operating time of any Company protection schemes that reach into the Facility. The Company will review the proposed operating time of the Facility's protection schemes and ascertain the performance requirements on a case by case basis.

G. Closed Transition Switching Installations

Some privately-owned generation may be paralleled only momentarily with the DEC system during part of a source or load transfer sequence. Generators used primarily for load reduction or emergency power are sometimes operated in this manner.

1. At the time of momentary parallel operation, these installations must meet the voltage, frequency and synchronization requirements outlined in preceding Section X1 , B, C, and D. The synchronizing may be manual for generators up to 10 MW if the closed transition is manually initiated. Otherwise, the synchronizing should be automatic.
2. The transition scheme must have an additional safeguard to limit the amount of time the generator is paralleled with the Grid. The scheme shall trip the generator if the closed transition mode remains in effect longer than some predetermined time DEC to which the Generator Owner is requesting interconnection will determine the allowable time span for parallel operation of the generator.

XIII. Protection Scheme Details

1. General

1. The protection schemes described in this Section are intended to be typical for illustration purposes and not specific design requirements for any particular site. They are intended to guide the proposed Generator Owner and provide basic information on the types of protection schemes necessary for generator Parallel Operation.
2. Protective relays, wherever possible, shall be microprocessor type with integral trip record and fault recording, self-checking and remote communications. Remote communications should be provided through a digital switching device to allow a single communication line to service multiple protective relays.
3. All protective relays must have the desired sensitivity and speed for its intended application and be of utility grade. The Company can provide feedback to the Generator Owner in this regard.
4. All equipment, lines and busses operating at 69 kV and above shall be protected by two independent protective schemes.
5. Primary and backup protection schemes shall be supplied via independent current/potential circuits and independently protected DC control circuits.
6. DC circuits supplying protective relaying schemes shall be continuously monitored and fused separately from any other DC control circuits. Loss of any control power bus including DC trip and close busses of each breaker shall also be monitored and alarmed to a manned location so that corrective action can be taken. Relay failure alarms shall be handled in a similar manner.

7. Generator units selling into the PJM marketplace, or interconnected at 69 kV and above, must meet the protection requirements detailed in the PJM Protective Relaying Philosophy and Design Standards document.
8. All protective relay systems, equipment, design, operation and maintenance shall be in accordance with all applicable Federal, State and Local requirements, National and Regional Reliability Criteria and Industry Recognized Standards and Guidelines. References to such requirements may be found in Section XV of this document. The listing is not intended to be all- inclusive.

2. Interface (Isolation) Transformer Protection

Typical protection schemes for various size Interface Transformers are illustrated below.

Table 4, Interface Transformer Protection

Up to 10 MVA	10 – 50 MVA	Greater than 50 MVA
<ul style="list-style-type: none"> • Three-Phase Protection Device (12 kV or 69 kV only) 	<ul style="list-style-type: none"> • Transformer Differential • Fault Pressure • Time/Inst. Over Current 	<ul style="list-style-type: none"> • Transformer Primary Differential • Transformer Backup Differential • Fault Pressure • Time/Inst. Over Current • Over Excitation

Notes:

- a) For transformers needing two differential protection schemes, one of the differential schemes may also include the generator.
- b) The location of the transformer over current relaying may be dependent on the transformer connections.
- c) Generators with a fuse protected Interface (Isolation) Transformer must include protection to detect an open fuse condition.

3. Interconnection Line Protection

The protection applied to a line terminal at the Generator Owner’s site that interconnects the privately-owned generator with the DEC system will vary depending on the voltage class and existing line relaying scheme at the DEC end(s).

Typical protection schemes for various voltage interconnection lines are provided in Table 5. The actual schemes used will vary for each specific site.

Table 5, Typical Line Terminal Protection Schemes

Line Voltage Class	Possible Line Protection Schemes
12 kV	<ul style="list-style-type: none"> • Phase & Ground Overcurrent (May need to be directional) • Three-Phase to Ground Connected Under Voltage & Over Voltage • (For line terminating in delta or ungrounded wye connected transformer)
69 kV	<ul style="list-style-type: none"> • Phase & Ground Directional Over current • Phase & Ground Distance Pilot (DCB, POTT, PUTT, DTT) • Phase & Ground Step Distance Backup • Three-Phase Overvoltage (For line terminating in delta or ungrounded wye connected transformer)
138 kV	<ul style="list-style-type: none"> • Phase & Ground Distance Pilot (DCB, POTT, PUTT, DTT) • Phase & Ground Step Distance Backup • Direct Transfer Trip Send/Receive

Notes:

- a) Generators that can go unstable due to delayed fault clearing if line pilot protection scheme fails will require two independent high speed pilot schemes, with independent communication channels.
- b) DCB is Directional Comparison Blocking
- c) POTT is Permissive Overreaching Transfer Trip
- d) PUTT is Permissive Under-Reaching Transfer Trip
- e) DTT is Direct Transfer Trip

4. Generator Isolation Detection Schemes

1. Under/over frequency and under/over voltage schemes can be used to detect the fact that the generator is Islanded with load (and possibly other generation) and needs to be disconnected from the DEC Grid.
2. Under/over frequency and under/over voltage detection becomes less reliable when the Islanded load is more closely matched to the generator capacity so that the resulting voltage and frequency is at or very near normal. In these cases, direct transfer trip from the DEC system to the Generator Owner’s site will be necessary.
3. Generators selling into the PJM marketplace that have their under frequency trip point set to meet PJM under frequency operational requirements (such as 57.5 Hz. for 5 Seconds) essentially removes under frequency sensing as a sensitive means to detect isolation. In this event, other protective measures, such as transfer trip, will be required.

4. Generators using dynamic inverters to regulate voltage at the Point of Interconnection generally will not conform to the requirements of IEEE 1547-2018 and thus will require transfer trip from the upstream protective device(s).
5. Generally, combinations of different protection schemes are necessary to be 100% effective and to provide a level of redundancy
6. In cases where a transfer tripping scheme is needed to ensure isolation detection, the failure of the transfer trip scheme or communication channel will require that the generator automatically disconnect from the DEC until the transfer trip scheme is restored.

5. Generator Protection Schemes

1. The protection schemes on generators will become more complex as the size of the generator unit increases. In addition, those generators selling into the PJM marketplace will require specific protection as required by PJM. The PJM Relay Subcommittee Protective Relaying Philosophy and Design Standards should be consulted.
2. Multi-function microprocessor relays can be used to provide several generator protection functions. However, a second multi-function relay (preferably from another manufacturer to avoid a common failure mode or defective algorithm) is necessary to provide for a relay failure. Alternatively, the generator could be immediately and automatically tripped off line upon a relay failure alarm and remain off line until the relay is repaired. This arrangement, however, may jeopardize the Generator Owner's ability to sell firm capacity into the PJM marketplace.
3. The Generator Owner should consult the generator manufacturer and national standards to develop the appropriate protection for each generator installation. National Standards include C37.102-2006 IEEE Guide for AC Generator Protection and C37.101-2006 IEEE Guide for Generator Ground Protection.
4. Some typical protection schemes for various size generators are noted in Table 6 on the following page. The actual schemes required for each site could vary from these representative samples.

Table 6, Typical Generator Protection Schemes

DC Generating Systems With Non-Islanding Inverters	Induction/Synchronous Generators Up to 10 MW	Synchronous Generators 10 MW up to 50 MW	Synchronous Generators 50 MW & Above
<ul style="list-style-type: none"> • Over/Under Voltage • Over/Under Frequency This preceding protection is integral to the Non-Islanding Inverter. • DC Overcurrent 	<ul style="list-style-type: none"> • Over/Under Voltage • Over/Under Frequency • Directional Power (Watt /Var) • Phase Overcurrent • Ground Overcurrent • Negative Sequence 	<ul style="list-style-type: none"> • Over/Under Voltage • Over/Under Frequency • Differential • Stator Ground • Loss of Field • Anti-Motoring • Negative Sequence • Voltage Controlled Overcurrent 	<ul style="list-style-type: none"> • Over/Under Voltage • Over/Under Frequency • Primary Differential • Back Up Differential • 100% Stator Ground • Back Up Stator Ground • Generator Lead Protection • Primary Loss of Field • Back Up Loss of Field • Field Ground • Anti-Motoring • Negative Sequence • Voltage Controlled Overcurrent or Distance Backup • Breaker Flashover • Protection During Unit Start Up & Shut Down • Accidental Energization • Out of Step Protection • Synchronizing Check (Ref. Appendix A)

Notes:

- a) On generators with primary and backup differentials, one differential may also cover the unit step up transformer.
- b) Loss of synchronism (out-of-step) protection is necessary where stability studies have shown this protection to be needed.
- c) Ancillary protection schemes such as breaker failure are also required.

XIV. Typical One-Line Diagrams

The One-Line Diagrams in Appendix E are intended to be typical or representative samples of various types and sizes of generation Facilities that are connected to and operate in parallel with the DEC system and do not purport to cover every possible case. Each site will have to be specifically designed taking into account the unique characteristics of each installation, the specific location of the Point of Common Coupling and the operating and contractual requirements for that site. Additional PJM and RFC requirements may also apply.

The listed voltages on the diagrams represent nominal values. The actual voltage is dependent on the interconnection location on the DEC circuit.

XV. Interconnection Application for non-PJM Generation Interconnection Projects

1. For non PJM generation interconnections, the proposed Generator Owner shall submit an Interconnection Application to the DEC for approval to connect and operate a generating unit in parallel with the DEC Grid. This application should be made as far in advance as possible of the tentative planned in service date. In general, the larger the proposed generating unit, the more lead time is needed to review all aspects of the interconnection and to finalize the Facility design. (The PJM application process is outside the scope of this document and the proposed Generator Owner will have to contact PJM directly on these issues. Information can also be found on the PJM website, www.pjm.com)
2. Early application submission can also be cost advantageous to the proposed Generator Owner. The DEC system near the proposed generator site may require extensive and costly upgrades in order to accommodate the output of the generator. These upgrade costs may make the proposed site undesirable for the project. Early application should make this adverse information known before the proposed Generator Owner has made extensive design and site purchase/work expenditures.
3. Early application submission is also advantageous to DEC and assists DEC in meeting the Generator Owner's time schedule. DEC will have to assign resources, do engineering and order material necessary for any Grid upgrades. The earlier this process is started, the easier it is for DEC to meet the Generator Owner's proposed in service date.
4. The Generator Owner shall complete an Interconnection Application Form and supply as much information as possible. It is realized that some information will probably not be available at the time of the initial application submission. However, the Generator Owner should supply as much information and details as possible and forward other necessary information as soon as it becomes available. For non PJM generation interconnections, the forms in Appendix B to this document should be used. For PJM queue projects, refer to the PJM Tariff for application forms and requirements.
5. For non PJM generation interconnections, a One-Line Diagram for the entire proposed Facility shall accompany the Interconnection Application. The diagram shall include details on the connection and rating of all equipment and show all protective schemes. In addition, transformer and generator impedance characteristics and dynamic modeling data must be submitted (see Appendix B).
6. Details on how the proposed Facility is to be operated and the anticipated range of power to be exported into DEC Grid should be included with the Interconnection Application.
7. DEC reserves the right to request additional data, information details and drawings necessary to fully review the proposed Facility and to insure coordination of all equipment with DEC Grid.

8. For non PJM generation interconnections, following submission of the Interconnection Application, DEC, the Generator Owner and the Generator Owner's technical consultants will institute a series of meetings to review and discuss the proposed Facility. The comments and feedback from DEC at these meetings will enable the Generator Owner to finalize his design and operating requirements. For PJM queue projects, the PJM process must be followed.
9. In addition to reviewing the data, drawings and specifications provided by the Generator Owner, DEC may elect to physically inspect the Generator Owner's site during and after construction to insure adherence to the information supplied.
10. All protection, control schemes, metering and RTU operations must be functionally tested and operating correctly before DEC can approve the Interconnection.
11. DEC reserves the right to witness testing of the Generator Owner's protection and control schemes and to request copies of any test data/results. In witnessing any testing, DEC assumes no liability as the full responsibility of Facility operation and protection rests with the Generator Owner.
12. The Generator Owner can interconnect with DEC Grid and commence parallel operation only after DEC has provided written approval to interconnect.

XVI. References

The references and standards listed below can provide technical requirements, support and insight into the safe, reliable interconnection of distributed and parallel generation with the DEC systems. These references should be reviewed by those individuals and/or firms contemplating parallel operation of generation with DEC for applicability to their installation. This listing is not intended to be all-inclusive. In cases where a referenced document has been updated, the most recent version of the document should be used.

- NFPA 70, National Electric Code® (NEC®)
- ANSI Std. C84.1-2016, *Electric Power Systems and Equipment – Voltage Ratings*
- ANSI/IEEE Std. C37.1-2007, *IEEE Standard for SCADA and Automation Systems*
- IEEE 100-2000, *IEEE Authoritative Dictionary of IEEE Standard Terms*
- IEEE Std. 141-1993, *IEEE Recommended Practice for Electric Power Distribution for Industrial Plants* (IEEE Red Book)
- IEEE Std. 242-2001, *IEEE Recommended Practice for Protection and Coordination of Industrial and Commercial Power Systems* (IEEE Buff Book)
- IEEE Std. 493-2007, *IEEE Recommended Practice for Design of Reliable Industrial and Commercial Power Systems* (IEEE Gold Book)
- IEEE Std. 519-2014, *IEEE Recommended Practice and Requirements for Harmonic Control in Electric Power Systems*

- IEEE Std. 1159-2009, *IEEE Recommended Practice for Monitoring Electric Power Quality*
- IEEE Std. 1547-2018, *IEEE Standard for Interconnection and interoperability of Distributed Energy Resources with Associated Electric Power Systems Interfaces*
- IEEE Std. 1547.1a-2015, *IEEE Standard Conformance Test Procedures for Equipment Interconnecting Distributed Resources with Electric Power Systems*
- IEEE Std. 1547.2-2008, *IEEE Application Guide for IEEE 1547*
- IEEE Std. 1547.3-2007, *IEEE Guide for Monitoring, Information Exchange and Control of Distributed Resources Interconnected with Electric Power Systems.*
- IEEE Std. 1547.4-2011, *IEEE Draft Guide for Design, Operation and Integration of Distributed Resource Island Systems with Electric Power Systems.*
- IEEE C2, National Electric Safety Code® (NESC®)
- IEEE Std. C37.2-2008, *IEEE Standard for Electric Power System Device Function Numbers, Acronyms and Contact Designations.*
- IEEE Std. C37.90-2005, *IEEE Standard for Relays and Relay Systems Associated with Electric Power Apparatus*
- IEEE Std. C37.90.1-2012, *IEEE Standard Surge Withstand Capability (SWC) Tests for Protective Relays and Relay Systems Associated with Electric Power Apparatus.*
- IEEE Std. C37.91-2008, *IEEE Guide for Protecting Power Transformers*
- IEEE Std. C37.93-2004, *IEEE Guide for Power System Protective Relay Applications of Audio Tones over Voice Grade Channels*
- IEEE Std. C37.95-2014, *IEEE Guide for Protective Relaying of Utility-Consumer Interconnections*
- IEEE Std. C37.101-2006, *IEEE Guide for Generator Ground Protection*
- IEEE C37.102-2006, *IEEE Guide for AC Generator Protection*
- IEEE C37.103-2015, *IEEE Guide for Differential and Polarizing Relay Circuit Testing*
- IEEE C37.104-2012, *IEEE Guide for Automatic Reclosing of Circuit Breakers for AC Distribution and Transmission Lines*
- IEEE C37.106-2003 (Reaff. 2009), *IEEE Guide for Abnormal Frequency Protection for Power Generating Plants*
- IEEE Std. C37.110-2007/Cor 1-2010, *IEEE Guide for the Application of Current Transformers Used for Protective Relaying Purposes Corrigendum 1: Corrections to Equation 18 and Equation 19*
- IEEE Std. C37.113-2015, *IEEE Guide for Protective Relaying Applications to Transmission Lines*

- IEEE C37.230-2007, *IEEE Guide for Protective Relaying Applications to Distribution Lines*
- IEEE C37.234-2009, *IEEE Guide for Protective Relay Applications for Power System Buses*
- IEEE Std. C57.13.1-2006, *IEEE Guide to Field Testing of Relaying Current Transformers*
- IEEE Std. C57.13.2-2005, *IEEE Standard Conformance Test Procedures for Instrument Transformers*
- IEEE Std. C57.13.3-2014, *IEEE Guide for Grounding of Instrument Transformer Secondary Circuits and Cases*
- UL 1741-2010, Underwriters Laboratories, Inc. *Inverters, Converters, Controllers and Interconnection System Equipment for Use with Distributed Energy Resources.*
- *PJM Protective Relaying DEC Philosophy and Design Standards*
- *PJM Relay Testing and Maintenance Practices*
- *PJM Transmission Substation and Line Design, Application and Maintenance Guidelines*
- *NERC & RFC Planning Standards*

Appendix A

DEC Power Delivery
Generator Protection Guidelines
For Units 50 MW and Above

DEC Power Delivery Generator Protection Guidelines
For Units 50 MW and Above

The following discussion and guidelines are intended to be a basis for considering what protection to apply to both new units and those being upgraded. The *PJM Relay Subcommittee Protective Relaying Philosophy and Design Standards* document is the basis for these guidelines.

Some specific protection applications may also be required as the result of consultation with the generator manufacturer.

Generator protection, like that on transmission lines, buses and transformers should be designed for reliability. This means an artful balance of dependability and security. Dependability is a measure of the protective relaying systems certainty to trip when required and security a measure of the ability not to trip falsely. The balancing of these two requirements involves consideration of independent ac current and voltage sources to the front line and backup relay schemes. Also independently protected dc control circuits should be used with the front-line and backup relay schemes.

In those cases which follow, if the need for both front-line and backup relays is not defined, one protective scheme will be adequate.

1.0 Generator Stator Fault Protection

1.1 General Consideration

Generator stator faults are very serious and cause costly damage. Because of the obvious importance of generators, the fault must be detected and cleared in the least amount of time possible. Because of the stored rotating energy of the generator, damage may occur after all the required breakers have been tripped.

1.2 Phase Fault Protection

Use a front-line current differential relay scheme and an independent backup differential scheme with independent current sources and independently protected dc control circuits. Each of these schemes should trip the generator breakers, excitation system and turbine valves.

1.3 Ground Fault Protection

High impedance grounding of generators is an accepted industry practice. This is done to limit the magnitude of ground fault current. Ground fault protection should include two independent relay schemes, employing independent current or voltage sources and independently protected dc control circuits. Each scheme should trip the generator breakers, excitation system and turbine valves.

2.0 Generator Rotor Field Protection

The generator rotor field winding is ungrounded. One ground on this field will not affect the generator's operation. The first ground, however, greatly increases the likelihood of a second ground occurring, causing imbalances and overheating. Generators should be equipped with rotor ground fault protection which will alarm only. Upon receipt of this alarm, the generator's load should be reduced to zero and the generator shut down as quickly as possible.

3.0 Generator Abnormal Operating Conditions

3.1 Loss of Field

Loss of field (loss of excitation) will result in loss of synchronism. Detection of this loss of field is usually done with impedance type relays. A front-line and independent backup scheme is required with each providing a simultaneous trip of the generator breakers, excitation system and turbine valves.

3.2 Unbalanced Currents

Unbalanced, or negative sequence currents, are the result of unbalanced loading. This could be the result of one phase open or unbalanced system faults which are not cleared properly. The unbalanced currents themselves cause generator rotor overheating. Protection requires a negative sequence time over current relay with sensitivity sufficient to detect unbalanced conditions exceeding the continuous rating of the generator. The protection should initiate an alarm at one level and a unit trip at a higher level.

3.3 Loss of Synchronism

Loss of synchronism, out of step and pole slipping are all synonymous and can result from transients, dynamic instability or loss of excitation. This condition can be damaging to the unit. Detailed stability studies can determine if out of step protection is required. As a rule, if an impedance swing enters the generator or step up transformer impedance, out of step protection is necessary. When out of step protection is required, the generator should be tripped within the first slip cycle.

3.4 Over Excitation

Excessive flux (over excitation) in the generator core can cause rapid overheating. Volts/Hertz is a measure of this condition. Two independent schemes should be used, each providing protection for the volts/hertz rating of the generator. An initial alarm followed by a simultaneous trip of the generator breakers, excitation system and turbine valves is recommended.

3.5 Reverse Power (Anti-Motoring)

Generator motoring is caused by the lack of energy supplied to the prime mover resulting in the electrical system driving the machine as a motor. Synchronous motoring will not damage the generator but will cause damage to the prime mover. Anti-motoring protection should initiate an alarm which will be followed after a defined time by a unit trip (generator breakers, excitation system and turbine valves).

3.6 Abnormal Frequencies

Generators can withstand off frequency operation for long periods of time, provided the load and voltage are reduced a sufficient amount. The turbine, however, can be subject to resonance caused by the off frequency operation. The usual frequency excursion is to a lower than 60 hertz operation. Automatic system wide load shedding is the primary protection against this condition. For protection of the turbine, under frequency relays set at 57.5 hertz and a five second tripping delay are required. For security, two under frequency relays connected in series for tripping and using independent voltage sources should be used. A sequential trip of the turbine valves, the excitation system and generator breakers are recommended.

4.0 Generator Breaker Failure Protection

Breaker failure protection must be provided for all relay initiated generator trips. It should be noted that all generator abnormalities that require the generator to be tripped will not result in an over current condition (off frequency, unbalanced currents, etc.). For these conditions, current actuated fault detectors lack sensitivity to monitor breaker open/close status and breaker auxiliary switches should be used instead.

5.0 Excitation System Tripping

All protective relay trips of the generator excitation system should trip redundant systems. This could be tripping the main field breaker and exciter field or simultaneous tripping of the main field breaker and activation of the de-excitation system.

6.0 Generator Open Breaker Flashover Protection

Open breaker flashover is more likely on generator breakers. Protection for this must be provided for all gas and/or air circuit breakers.

7.0 Protection During Start Up or Shutdown

During start up or shut down the generator may be operated at less than rated frequency. During this time, adequate protection must be provided. Some relays, however, are frequency sensitive. Each of the relays' operating characteristics versus frequency must be checked to ensure proper operation at frequencies below 60 Hz. If relay operation is questionable, additional protective relaying will have to be added.

8.0 Protection for Accidentally Energizing a Generator on Turning Gear

Accidental energizing of a generator while off line or on turning gear has become of increasing concern in recent years. Severe damage to the generator can occur in a very short time. To provide adequate protection for accidental energization, a scheme designed specifically for this is required. This scheme must trip all associated generator breakers.

9.0 Synchronizing Equipment

Each generator should be equipped with a scheme that supervises manual synchronizing. For system emergency restoration, the generator breakers should be capable of closing on a dead system.

10.0 Generator Lead Protection

The generator lead, in other words, the phase conductors from the generator terminals to the unit power transformer and the unit auxiliary transformer should be protected by a primary current differential relay scheme. A backup differential relay scheme is required if:

10.1 The conductors are not segregated into bus ducts for their entire exposure, or

10.2 The generator is not grounded through a high impedance to limit ground faults to levels undetectable by current differential relays.

A simultaneous trip of the generator breakers, excitation system and turbine valves are recommended.

Appendix B

Information to Be Supplied By Generator Owner
For Projects 500 kW and Greater

Information to be Supplied by Generator Owner for Non-PJM Projects

The following information must be supplied by the Generator Owner to allow DEC to conduct necessary studies and reviews to assess the impact of the proposed Facility on the DEC system and to quantify what, if any, upgrades are required to accommodate the proposed generation addition at the specified Point of Common Coupling.

It is recognized that some information will not be available at the time of initial application submission. However, the Generator Owner should supply as much information and detail as possible and forward other necessary information as soon as it becomes available.

At the very least, data requested in Sections A through G, H.1 and L should accompany the initial application submission.

- A. Name of Generator Owner
- B. Name, address, telephone number, and E-mail address of individual able to answer technical questions relating to the design and operation of the proposed Facility
- C. Exact location of proposed Point of Common Coupling
- D. Type (Synchronous, Induction, Inverter, etc.) and rating of proposed generator(s)
- E. Estimated maximum and minimum Facility load at Point of Common Coupling with generation in service
- F. Estimated maximum and minimum Facility load at Point of Common Coupling without generation in service
- G. Estimated maximum power anticipated to be exported into the DEC system
- H. The Generator Owner shall provide copies of the following drawings to DEC for their review:
 - 1. A one-line diagram of Facility
 - 2. All potential elementary drawings associated with the protection and control schemes for the generator and interconnection equipment
 - 3. All current elementary drawings associated with the protection and control schemes for the generator and interconnection equipment
 - 4. A control elementary of the generator breaker and the interconnection breaker
 - 5. A three-line diagram of generation system

- I. The One-Line Diagram And Three-Line Diagram shall include the following information:
1. Equipment names and/or numerical designations for all circuit breakers, contactors, air switches, transformers, generators, etc. associated with the generation as required by DEC to facilitate switching.
 2. Power Transformers – name or designation, nominal kVA, nominal primary, secondary, tertiary voltages, vector diagram showing winding connections, tap setting and transformer impedance. A copy of the transformer nameplate and test report can be substituted.
 3. Station Service Transformers – Designate phase(s) connected to an estimated kVA load.
 4. Instrument Transformers – Voltage and current, phase connections.
 5. Surge Arresters/Gas Tubes/Metal Oxide Varistors/Avalanche Diode/Spill Gaps/Surge Capacitors, etc. – Type and Ratings.
 6. Capacitor Banks – kVAR rating.
 7. Disconnect Switches – Indicate status normally open with a (N.O.) and whether manual or motor operated. Include switch voltage, continuous and interrupting ratings.
 8. Circuit Breakers and/or Contactors – Interrupting rating, continuous rating, operating times.
 9. Generators(s) – Include nameplate, test report, type, connection, kVA, voltage, current, rpm, PF, impedances, time constants, etc.
 10. Point of Common Coupling with the DEC system and phase identification.
 11. Fuses – Manufacturer, type, size, speed, and location.
- J. Elementary Diagrams shall include the following information:
1. Terminal designation of all devices (relay coils and contacts, switches, transducers, etc.)
 2. Relay functional designation per latest ANSI Standard. The same functional designation shall be used on all drawings showing the relay.
 3. Complete relay type (such as CV-2, SEL321-1, REL-301, IJS51A, etc.)
 4. Switch contact shall be referenced to the switch development if development is shown on a separate drawing.
 5. Switch developments and escutcheons shall be shown on the drawing where the majority of contacts are used. Where contacts of a switch are used on a separate drawing, that drawing should be referenced adjacent to the contacts in the switch development. Any contacts not used should be referenced as spare.

6. All switch contacts are to be shown open with each labeled to indicate the positions in which the contact will be closed.
 7. Explanatory notes defining switch coordination and adjustment where mis-adjustment could result in equipment failure or safety hazard.
 8. Auxiliary relay contacts shall be referenced to the coil location drawing if coil is shown on a separate drawing. All contacts of auxiliary relays should be shown and the appropriate drawing referenced adjacent to the respective contacts.
 9. Device auxiliary switches (circuit breakers, contactor) should be referenced to the drawing where they are used.
 10. Any interlocks electromechanical, key, etc., associated with the generation or interconnection substation.
 11. Ranges of all timers and setting if dictated by control logic.
 12. All target ratings; on dual ratings note the appropriate target tap setting.
 13. Complete internal for electromechanical protective relays. Microprocessor relays may be shown as a “black box”, however, manufacturer’s instruction book number shall be referenced and terminal connections shown.
 14. Isolation points (states links, PK-2 and FT-1 blocks), etc., including terminal identification.
 15. All circuit elements and components, with device designation, rating and setting where applicable. Coil voltage is shown only if different from nominal control voltage.
 16. Size, type, rating and designation of all fuses.
 17. Phase sequence designation as ABC or CBA.
 18. Potential transformers – nameplate ratio, polarity marks, rating, primary and secondary connections (see Guidelines for minimum ratings.)
 19. Current transformers (including auxiliary CTs) – polarity marks, rating, tap ratio and connection.
- K. Documentation of all protective device settings shall be provided. The setting documentation shall also include relay type, model/catalog number and setting range. If automatic transfer schemes, unique or special protective schemes are used, a description of their operation should be included. DEC must review and approve the settings of all protective devices and automatic control equipment which (1) serve to protect the DEC system from hazardous currents and voltages originating from the Facility, or (2) must coordinate with protective devices or control equipment located on the DEC system.

- L. The following modeling data must be supplied to DEC and/or PJM to allow necessary interconnection studies to be performed. It is recognized that some of this data may initially be preliminary in nature. Interconnection studies will be based on data submitted. Any changes or modifications to this data after the interconnection study has been completed may render the analysis invalid and require re-opening of the interconnection study. It is the Generator Owners responsibility to make DEC and/or PJM aware of any changes to this data, and to provide final certified test reports and modeling data as soon as it is available.

Unit Capability Data

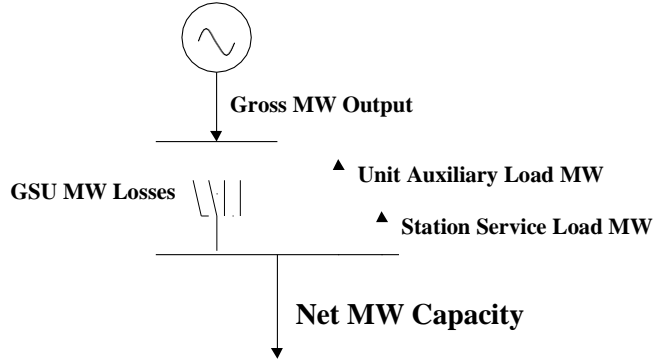

Net MW Capacity = (Gross MW Output - GSU MW Losses – Unit Auxiliary Load MW - Station Service Load MW)

PJM Queue Letter/Position/Unit ID: _____

Primary Fuel Type: _____

Maximum Summer (92° F ambient air temp.) Net MW Output: _____

Maximum Summer (92° F ambient air temp.) Gross MW Output: _____

Minimum Summer (92° F ambient air temp.) Gross MW Output: _____

Maximum Winter (30° F ambient air temp.) Gross MW Output: _____

Minimum Winter (30° F ambient air temp.) Gross MW Output: _____

Gross Reactive Power Capability at Maximum Gross MW Output (Leading and Lagging): _____

***** Please submit Reactive Capability Curve when available**

Individual Unit Auxiliary Load at Maximum Summer MW Output (MW/MVAR): _____

Individual Unit Auxiliary Load at Minimum Summer MW Output (MW/MVAR): _____

Individual Unit Auxiliary Load at Maximum Winter MW Output (MW/MVAR): _____

Individual Unit Auxiliary Load at Minimum Winter MW Output (MW/MVAR): _____

Station Service Load (MW/MVAR): _____

Please provide any comments on the expected capability of the unit:

Unit Generator Dynamics Data

PJM Queue Letter/Position/Unit ID: _____

MVA Base (upon which all reactance, resistance and inertia are calculated): _____

Nominal Power Factor: _____

Terminal Voltage (kV): _____

Unsaturated Reactance's (on MVA Base)

Direct Axis Synchronous Reactance, $X_{d(i)}$: _____

Direct Axis Transient Reactance, $X'_{d(i)}$: _____

Direct Axis Sub-transient Reactance, $X''_{d(i)}$: _____

Quadrature Axis Synchronous Reactance, $X_{q(i)}$: _____

Quadrature Axis Transient Reactance, $X'_{q(i)}$: _____

Quadrature Axis Sub-transient Reactance, $X''_{q(i)}$: _____

Stator Leakage Reactance, X_l : _____

Negative Sequence Reactance, $X_{2(i)}$: _____

Zero Sequence Reactance, X_0 : _____

Saturated Sub-transient Reactance, $X''_{d(v)}$ (on MVA Base): _____

Armature Resistance, R_a (on MVA Base): _____ at _____ °C

Time Constants (seconds)

Direct Axis Transient Open Circuit, T'_{do} : _____

Direct Axis Sub-transient Open Circuit, T''_{do} : _____

Quadrature Axis Transient Open Circuit, T'_{qo} : _____

Quadrature Axis Sub-transient Open Circuit, T''_{qo} : _____

Inertia, H (kW-sec/kVA, on KVA Base): _____

Speed Damping, D : _____

Saturation Values at Per-Unit Voltage [$S(1.0)$, $S(1.2)$]: _____

Please submit generator certified test report information when available

IEEE dynamic model parameters:

Governor Model: _____

Exciter Model: _____

Power System Stabilizer Model: _____

Unit Transformer Data

PJM Queue Letter/Position/Unit ID: _____

Generator Step-up Transformer MVA Base: _____

Generator Step-up Transformer Impedance (R+jX, on transformer MVA Base): _____

Generator Step-up Transformer Rating (MVA): _____

Generator Step-up Transformer Low-side Voltage (kV): _____

Generator Step-up Transformer High-side Voltage (kV): _____

Generator Step-up Transformer Off-nominal Turns Ratio: _____

Generator Step-up Transformer Number of Taps and Step Size: _____

Please submit transformer certified test report information when available

In addition, please indicate whether the transformer is shared with other units.

Appendix C

Generator Interconnection Application for Use
With Generators Less than 100 kW

Delaware Electric Cooperative, Inc.
Interconnection Application
(For Use with Systems Less than 100 kW AC)
REVISED August 2018

This Interconnection Application also serves as a binding contract between Delaware Electric Cooperative, Inc. (hereinafter referred to as DEC) and each signatory listed herein.

General Instructions and Expectations

1. The preliminary portion of this application (Sections 1 through 12) and Addendum A must be submitted initially along with the application fee or a scanned copy of the check (see Section 6) to:

Delaware Electric Cooperative, Inc.
ATTN: Interconnection Application
PO Box 600
Greenwood, DE 19950

Email: interconnection@delaware.coop

2. Should any Interconnection Application require multiple revisions by the Equipment Contractor and subsequent reviews, DEC reserves the right to charge a \$50 fee for each additional review.
3. Any Generating System requiring an upgrade to the DEC utility system will require the cooperative member to request that specific upgrade. Payment in full for all costs associated with the requested upgrade is required before construction of the Generating System is permitted to begin.
4. After the preliminary portion of this application (Sections 1 through 12) has been approved by DEC and returned to the Equipment Contractor, construction of the Generating System may begin.
5. The final portion of this application (Sections 1 through 14) and a scanned copy of the Inspection Certificate (if applicable) must be submitted for final approval after construction of the Generating System is complete. Upon submittal, DEC will meet with the Equipment Contractor to perform a field inspection of the installation. Any installations deemed unacceptable to DEC's standards, or any installation that alters the original, approved design intent will be corrected by the Equipment Contractor at no cost to DEC before final approval is granted.
6. When final approval is granted, DEC will install a net meter and return the approved Interconnection Application to the Equipment Contractor. Only at that time, will "Permission to Operate" be granted.

Delaware Electric Cooperative, Inc.
Interconnection Application
(For Use with Systems Less than 100 kW AC)
Revised August 2018

7. This application must be filled out in its entirety or it will be returned without review.

Type of Application: Initial _____ or Addition/Upgrade _____
Ownership: Leased _____ or Member-Owned _____
Account(s): Single _____ or Aggregated _____

1. DEC Member Information

Name: _____

Address: _____

Town: _____ State: _____ Zip: _____

Email: _____ Phone: _____

DEC Account Number: _____

Sq Ft of Residence: _____ Electric Heat? Yes _____ No _____

2. Equipment Contractor Information

Name: _____

Address: _____

Town: _____ State: _____ Zip: _____

Email: _____ Phone: _____

3. Electrical Contractor Information (If different from above)

Name: _____

Address: _____

Town: _____ State: _____ Zip: _____

Email: _____ Phone: _____

Delaware Electric Cooperative, Inc.
Interconnection Application
(For Use with Systems Less than 100 kW AC)
REVISED August 2018

4. Facility Information *(If different from above)*

Address:

Town: _____ State: _____ Zip: _____

Nearest DEC Equipment Tag Number: _____

5. General Service Requirements

What size service is required for this system?

Same as existing _____ 200A _____ 320A _____ 400A _____ 600A _____

CT Metering _____

If this is a new account for the sole purpose of this Generating System, what Voltage/Phase will be required?

120/240V – 1Ø _____

120/208V – 1Ø _____

120/208V – 3Ø _____ (Consult DEC before designing 3Ø systems)

277/480V – 3Ø _____ (Consult DEC before designing 3Ø systems)

6. Application Fee

The application fee is \$50.00 per application for new or upgraded systems 25 kW DC or less. For systems over 25 kW DC the fee will be \$50.00 plus \$1.00 for each kW DC over the initial 25 kW DC. The application fee for systems where accounts will be aggregated is \$125 per application regardless of kW DC size. All Interconnection Applications submitted to DEC shall be accompanied with the appropriate fee made payable to DEC. The application fee is non-refundable. Applications returned for incomplete information will be subject to an additional \$50 application fee when resubmitted. No applications will be considered without the application fee. Returned checks will be assessed an additional fee based on DEC's Returned Check Policy.

Delaware Electric Cooperative, Inc.
Interconnection Application
(For Use with Systems Less than 100 kW AC)
REVISED August 2018

7. Equipment Information

Is this equipment powered from a renewable source? Yes ____ No ____
Type of energy source:

Solar ____ Wind ____ Diesel ____ Natural Gas ____ Fuel Oil ____ Other ____

Will excess power be exported to DEC? Yes ____ No ____

(Typical) Maximum export: _____ kW DC/AC

24 month average usage (kWh) _____ (monthly)

Forecast *monthly* production (kWh) _____

(Note: The forecast monthly SOLAR production MUST be completed using **4.5 peak sunlight hours per day**)

Generator (or solar collector) Manufacturer, Model Name, and Number:

(A copy of the generator nameplate and manufacturer's specification sheet may be substituted)

Quantity of PV Modules: _____ Size of PV Modules: _____

Inverter Manufacturer, Model Name, and Number:

(A copy of the inverter nameplate and manufacturer's specification sheet may be substituted)

Quantity of Inverters: _____

Please fill out the Initial Rating information if there is currently no Generating System on-site. If adding a Generating System to an existing system, fill out the Initial Rating information, the Added Rating information, and the Total Rating information.

Initial Rating:

DC System Design Capacity _____ (kW)
AC System Design Capacity _____ (kW) _____ (kVA)

Added Rating:

DC System Design Capacity _____ (kW)
AC System Design Capacity _____ (kW) _____ (kVA)

Total Rating:

DC System Design Capacity _____ (kW)
AC System Design Capacity _____ (kW) _____ (kVA)

Delaware Electric Cooperative, Inc.
Interconnection Application
(For Use with Systems Less than 100 kW AC)
REVISED August 2018

In order to comply with Delaware State Law regarding output of an interconnection Facility, DEC uses the following formula:

- | | | |
|--|-------|--|
| 1. Enter the 24 month average usage (kWh): | _____ | (Per month) |
| 2. Multiply line 1 by 110%: | _____ | (Maximum output permitted by Delaware law) |
| 3. Enter maximum inverter rating (kVA): | _____ | (From nameplate, at appropriate voltage) |
| 4. Multiply line 3 by 4.5 (hours): | _____ | (This is the maximum kWh possible per day) |
| 5. Multiply line 4 by 365 (days): | _____ | (This is the maximum kWh possible per year) |
| 6. Divide line 5 by 12 (months): | _____ | (This is the maximum kWh possible per month) |

If line six (6) is equal to or less than line two (2), the system, as designed, will be approved by DEC.

For DEC members that have greater than 12 months of usage history and less than 24 months of usage history, the most recent 12 months of usage history shall be used to obtain the average monthly usage necessary for calculating the inverter size as described above.

For DEC members that have no usage or less than 12 months of usage history, please consult DEC before designing the Generating System.

8. Generator Disconnect Switch

A lockable disconnect device shall be installed within three (3) feet of the DEC meter and accessible at all times by DEC personnel. The cost of this device and the installation thereof shall not be the responsibility of DEC.

9. Equipment Certification

Equipment that utilizes inverter technology must be compliant with *IEEE 929* and *Underwriters Lab. UL1741*. Equipment that utilizes a rotating machine must be compliant with DEC's *Technical Requirements for Parallel Operation of Member Owner Generation* document.

By signing below, the Equipment Contractor certifies that the installed generating equipment meets the appropriate preceding requirement(s) and can supply documentation that confirms compliance.

Company: _____

Name (print): _____ Date: _____

Signature: _____

Delaware Electric Cooperative, Inc.
Interconnection Application
(For Use with Systems Less than 100 kW AC)
REVISED August 2018

10. Aggregate Meter Information (if applicable)

The following accounts shall be combined for the purpose of determining the twenty-four (24) months average usage (kWh) as required in the aforementioned formula regarding inverter sizing. Any surplus energy produced by the Generating System will be credited back to the accounts listed below. Each account must be active and ranked according to the order in which credit shall be applied. The specific method of remuneration will be determined by Delaware State Law, the DEC Tariff, and member approval.

1. Name: _____ Rate: _____
Account No. _____
24 month average usage (kWh): _____ (monthly)
2. Name: _____ Rate: _____
Account No. _____
24 month average usage (kWh): _____ (monthly)
3. Name: _____ Rate: _____
Account No. _____
24 month average usage (kWh): _____ (monthly)
4. Name: _____ Rate: _____
Account No. _____
24 month average usage (kWh): _____ (monthly)
5. Name: _____ Rate: _____
Account No. _____
4 month average usage (kWh): _____ (monthly)

Any additional meters associated with the aggregated system must be supplied on a separate sheet in the same format.

Delaware Electric Cooperative, Inc.
Interconnection Application
(For Use with Systems Less than 100 kW AC)
REVISED August 2018

11. Signatures

DEC Member

I hereby certify that, to the best of my knowledge, all the information provided in this Interconnection Application is true and correct.

Name (print): _____

Date: _____

Signature: _____

Equipment Contractor

I hereby certify that the information regarding the Generating System is complete, accurate, and shall be installed as designed in accordance with all applicable standards.

Name (print): _____

Date: _____

Signature: _____

Electrical Contractor (if different from above)

I hereby certify that all wiring and installation of associated equipment shall be completed in compliance with all applicable *NEC* codes.

Name (print): _____

Date: _____

Signature: _____

12. PRELIMINARY Approval to Proceed with Interconnection

Returned without review due to insufficient information: _____
Delaware Electric Cooperative: Has Approved ____ Has Not Approved ____
this preliminary application.

Reason for not approving:

Name (print): _____

Date: _____

Signature: _____

Delaware Electric Cooperative, Inc.
Interconnection Application
(For Use with Systems Less than 100 kW AC)
REVISED August 2018

13. Installation Details

The Generating System will be installed by: Owner: _____
State Licensed Electrician: _____
Installing Electrician: _____
Company: _____ License No.: _____
Mailing Address: _____
Town: _____ State: _____ Zip: _____
Email: _____ Phone: _____

Supply certification that the generating system has been installed and inspected in compliance with the local Building/Electrical code of the municipality of _____.

Signed (Inspector): _____ Date: _____
(In lieu of signature of Inspector, a copy of the final inspection certificate may be attached)

14. FINAL Approval or Non-Approval

Delaware Electric Cooperative: Has Approved ____ Has Not Approved ____
this interconnection application.

Name: _____ Date: _____
Signature: _____

Reason for not approving this Interconnection Application: _____

“Permission to Operate” has been granted as of: _____

ADDENDUM A- INTERCONNECTION AGREEMENT TERMS AND CONDITIONS

1. **Scope of Agreement.** The Interconnection Application (“Application”) and this Addendum (collectively the “Agreement”) establish the conditions pursuant to which Delaware Electric Cooperative (hereinafter “DEC”) and _____ (hereinafter “Member”) agree that the electric generating facilities (the “Facilities”) listed in the Application may be interconnected to DEC’s electric distribution system (“System”).

2. **Establishment of Point of Interconnection.** The point where the electric energy first leaves the wires or facilities owned by DEC and enters the wires or facilities provided by Member is the “Point of Interconnection.” DEC shall determine the Point of Interconnection in accordance with its rules, regulations, by-laws, rates, and Tariffs (the “Rules”), which are incorporated herein by reference. Any interconnection equipment installed by Member (“Interconnection Facilities”) shall also be in accordance with the Rules.

3. **Responsibilities of DEC and Member for Installation, Operation and Maintenance of Facilities.** Member will, at its own cost and expense, install, operate, maintain, repair, and inspect, and shall be fully responsible for, the Facilities listed in the Application and Member’s Interconnection Facilities. Member’s Facilities shall be designed, installed, maintained and operated in a safe and reliable manner, in compliance with all aspects of the Rules, and in accordance with industry standard prudent engineering practice. Maintenance of the Facilities and Interconnection Facilities shall be performed in accordance with the applicable manufacturers’ recommended maintenance schedule.

Member also agrees that the design, installation, maintenance and operation of its Facilities and Interconnection Facilities shall minimize the likelihood of a malfunction or other disturbance, damaging or otherwise affecting or impairing the System. Member shall comply with all applicable laws, regulations, zoning codes, building codes, safety rules and environmental restrictions applicable to the design, installation, operation and maintenance of its Facilities and Interconnection Facilities. Member shall obtain all environmental and other permits lawfully required by governmental authorities prior to the commencement of construction of the Facilities and Interconnection Facilities.

DEC will notify Member if there is evidence that operation of the Facilities or Interconnection Facilities causes, or may cause, disruption or deterioration of service to other members of DEC served by the System, or if operation of the Facilities or Interconnection Facilities causes, or may cause, damage or impairment to the System. Member will notify DEC of any emergency or hazardous condition or occurrence with the Facilities or Interconnection Facilities, which could affect safe operation of the System.

4. **Modifications.** Member will not increase the output of the Facilities or make other material changes or modifications to the configuration or operation of the Facilities or Interconnection Facilities without the prior written consent of DEC. In the event that Member plans to undertake a modification that reasonably may be expected to impact the System, Member shall provide DEC with sufficient information to allow DEC to evaluate the potential impact of the modification prior to commencement of any work.

5. **Net Metering.** All power sales to DEC and net metering shall be governed by DEC’s Tariff and Delaware law, Chapter 10 of Title 26 (Electric Utility Restructuring). Interconnection of the Facilities with the System does not grant Member the right to export power in excess of the applicable limits set forth in DEC’s Tariff of Delaware law, Chapter 10 of Title 26 (Electric Utility Restructuring), nor does it constitute an agreement by DEC to purchase or wheel excess power.

6. **Limitation of Liability and Indemnification.** (a) Member shall be responsible for the safe installation, maintenance, repair and condition of the Facilities and Interconnection Facilities. DEC does not assume any duty of inspecting Member’s lines, wires, switches, or other equipment or property and will not be responsible therefor. Member assumes all liability for and shall indemnify DEC and its members,

directors, officers, managers, employees, agents, representatives, affiliates, successors and assigns for and shall hold them harmless from and against any claims, losses, costs, and expenses of any kind or character that are the result from Member's negligence or other wrongful conduct in connection with the design, construction, installation, operation or maintenance of the Facilities or Interconnection Facilities. Such indemnity shall include, but is not limited to, financial responsibility for (i) monetary losses; (ii) reasonable costs and expenses of defending an action or claim; (iii) damages related to death or injury; (iv) damages to property; and (v) damages for the disruption of business.

DEC's liability to the other party for any loss, cost, claim, injury, liability, or expense, including reasonable attorney's fees, relating to or arising from any act or omission in its performance of this Agreement, shall be limited to the amount of direct damages actually incurred. In no event shall DEC be liable to Member any indirect, incidental, special, consequential, or punitive damages of any kind whatsoever. Member shall indemnify, defend, and save DEC harmless from any and all damages, losses, claims, including claims and actions relating to injury to or death of any person or damage to property, demand, suits, recoveries, costs and expenses, court costs, attorney fees, and all other obligations by or to third parties, arising out of or resulting from the construction, design, installation, operation and maintenance of the Facilities.

7. **Right of Access, Equipment Installation, Removal & Inspection.** DEC may send employees, agents or contractors to Member's premises at any time, whether before, during or after the time the Facilities first produce energy to inspect the Facilities and Interconnection Facilities. DEC may monitor and observe the Facility's installation, commissioning (including any testing), startup, operation, and maintenance. DEC shall at all times have direct, unabated access to the disconnect switch and metering equipment of the Facility. DEC shall provide reasonable notice to Member when possible prior to exercising its right of access.

8. **Disconnection of Facilities.**

(a) DEC may temporarily disconnect the Facilities upon any of the following conditions:

- 1) For scheduled outages upon reasonable notice;
- 2) For unscheduled outages or emergency conditions;
- 3) If the Facilities or Interconnection Facilities do not operate in a manner consistent with the Application or these Terms and Conditions;
- 4) For improper installation or if the Facilities or Interconnection Facilities create a safety, reliability or a power quality problem; or
- 5) The Member's Interconnection Facilities are de-listed by the Nationally Recognized Testing Laboratory that provided the listing at the time the interconnection was approved.

(b) DEC may permanently disconnect or direct Member to disconnect Member's Facility and Interconnection Facilities if this Agreement is terminated.

9. **Governing Law, Regulatory Authority, and Rules.** The validity, interpretation and enforcement of this Agreement and each of its provisions shall be governed by the laws of the State of Delaware. Nothing in this Agreement is intended to affect any other agreement between DEC and Member. However, in the event that a provision of the Agreement conflicts with any provision of DEC's Tariff, the Tariff shall control.

10. **Termination.** This Agreement may be terminated under the following conditions:

- (a) By Member: Member may terminate Agreement at any time by providing written notice to DEC;
- (b) By DEC: DEC may terminate this Agreement if Member fails to remedy a violation of the terms of this Agreement within 30 calendar days after notice, or such other date as may be mutually agreed to prior to the expiration of the 30 day period.

11. **Severability.** If any provision or portion of this Agreement shall for any reason be held or adjudged to be invalid or illegal or unenforceable by any court of competent jurisdiction or other governmental authority, (i) such portion or provision shall be deemed separate and independent, (ii) the Parties shall negotiate in good faith to restore insofar as practicable the benefits to each Party that were affected by such ruling, and (iii) the remainder of this Agreement shall remain in full force and effect.

12. **Entirety of Agreement; Amendments.** This Agreement, including the Rules, which are expressly made a part hereof for all purposes, constitutes the entire agreement and understanding between the Parties with regard to the interconnection of the Facilities. No amendments or modifications to this Agreement shall be effective unless in writing and signed by the Parties hereto.

13. **Notices.** Notices given under this Agreement are deemed to have been duly delivered if hand delivered or sent by United States certified mail, return receipt requested, postage prepaid, to Member at the address listed in the Application and to DEC at P.O. Box 600, Sussex Highway, Greenwood, Delaware 19950.

14. **Member Certification.** I hereby certify that: 1) I have read and understand the Terms and Conditions of the Agreement; 2) I have read and understand the Technical Requirements for Member-Owned Generation; 3) I agree to comply with all provisions of the Terms and Conditions; and 4) to the best of my knowledge and belief, all information provided by me in the Application is true and complete.

Member Signature

Printed Name

Date: _____

Appendix D

Generator Interconnection Application
For use with Generators 100 kW to 500 kW AC

Delaware Electric Cooperative, Inc.

Interconnection Application

(For Use with Systems 100 kW AC to 500 kW AC)

REVISED August 2018

This Interconnection Application also serves as a binding contract between Delaware Electric Cooperative, Inc. (hereinafter referred to as DEC) and each signatory listed herein.

General Instructions and Expectations

1. The preliminary portion of this application (Sections 1 through 12) and Addendum A must be submitted initially along with the application fee or a scanned copy of the check (see Section 6) to:

**Delaware Electric Cooperative, Inc.
ATTN: Interconnection Application
PO Box 600
Greenwood, DE 19950**

Email: interconnection@delaware.coop

2. Should any Interconnection Application require multiple revisions by the Equipment Contractor and subsequent reviews, DEC reserves the right to charge a \$125 fee for each additional review.
3. Any Generating System requiring an upgrade to the DEC utility system will require the cooperative member to request that specific upgrade. Payment in full for all costs associated with the requested upgrade is required before construction of the Generating System is permitted to begin.
4. After the preliminary portion of this application (Sections 1 through 12) has been approved by DEC and returned to the Equipment Contractor, construction of the Generating System may begin.
5. The final portion of this application (Sections 1 through 14) and a scanned copy of the Inspection Certificate (if applicable) must be submitted for final approval after construction of the Generating System is complete. Upon submittal, DEC will meet with the Equipment Contractor to perform a field inspection of the installation. Any installations deemed unacceptable to DEC's standards, or any installation that alters the original, approved design intent will be corrected by the Equipment Contractor at no cost to DEC before final approval is granted.
6. When final approval is granted, DEC will install a net meter and return the approved Interconnection Application to the Equipment Contractor. Only at that time, will "Permission to Operate" be granted.
7. This application must be filled out in its entirety or it will be returned without review.

Delaware Electric Cooperative, Inc.

Interconnection Application

(For Use with Systems 100 kW AC to 500 kW AC)

REVISED August 2018

Type of Application: Initial _____ or Addition/Upgrade _____
Ownership: Leased _____ or Member-Owned _____
Account(s): Single _____ or Aggregated _____

1. DEC Member Information

Name: _____

Address: _____

Town: _____ State: _____ Zip: _____

Email: _____ Phone: _____

DEC Account Number: _____

Sq. Ft of Residence: _____ Electric Heat? Yes _____ No _____

2. Equipment Contractor Information

Name: _____

Address: _____

Town: _____ State: _____ Zip: _____

Email: _____ Phone: _____

3. Electrical Contractor Information (If different from above)

Name: _____

Address: _____

Town: _____ State: _____ Zip: _____

Email: _____ Phone: _____

4. Facility Information (If different from above)

Address: _____

Town: _____ State: _____ Zip: _____

Nearest DEC Equipment Tag Number: _____

5. General Service Requirements

What size service is required for this system?

Same as existing _____ 200A _____ 320A _____ 400A _____ 600A _____

CT Metering _____

If this is a new account for the sole purpose of this Generating System, what Voltage/Phase will be required?

- 120/240V – 1Ø _____
- 120/208V – 1Ø _____
- 120/208V – 3Ø _____ (Consult DEC before designing 3Ø systems)
- 277/480V – 3Ø _____ (Consult DEC before designing 3Ø systems)

6. Application Fee

The application fee is \$125.00 per application for new or upgraded systems 100 kW DC or greater. For systems over 100 kW DC the fee will be \$125.00 plus \$1.00 for each kW DC over the initial 100 kW DC. All Interconnection Applications submitted to DEC shall be accompanied with the appropriate fee made payable to DEC. The application fee is non-refundable. Applications returned for incomplete information will be subject to an additional \$125 application fee when resubmitted. No applications will be considered without the application fee. Returned checks will be assessed an additional fee based on DEC’s Returned Check Policy.

7. Equipment Information

Is this equipment powered from a renewable source? Yes _____ No _____

Type of energy source:

Solar _____ Wind _____ Diesel _____ Natural Gas _____ Fuel Oil _____ Other _____

Will excess power be exported to DEC? Yes _____ No _____

(Typical) Maximum export: _____ kW DC/AC

24 month average usage (kWh) _____ (monthly)

Forecast *monthly* production (kWh) _____

(Note: The forecast monthly SOLAR production MUST be completed using ***4.5 peak sunlight hours per day***)

Generator (or solar collector) Manufacturer, Model Name, and Number:

(A copy of the generator nameplate and manufacturer’s specification sheet may be substituted)

Quantity of PV Modules: _____ Size of PV Modules: _____

Inverter Manufacturer, Model Name, and Number:

(A copy of the inverter nameplate and manufacturer’s specification sheet may be substituted)

Quantity of Inverters: _____

Please fill out the Initial Rating information if there is currently no Generating System on-site. If adding a Generating System to an existing system, fill out the Initial Rating information, the Added Rating information, and the Total Rating information.

Initial Rating:

DC System Design Capacity _____ (kW)
AC System Design Capacity _____ (kW) _____ (kVA)

Added Rating:

DC System Design Capacity _____ (kW)
AC System Design Capacity _____ (kW) _____ (kVA)

Total Rating:

DC System Design Capacity _____ (kW)
AC System Design Capacity _____ (kW) _____ (kVA)

In order to comply with Delaware State Law regarding output of an interconnection Facility, DEC uses the following formula:

1. Enter the 24 month average usage (kWh): _____ (Per month)
2. Multiply line 1 by 110%: _____ (Maximum output permitted by Delaware law)
3. Enter maximum inverter rating (kVA): _____ (From nameplate, at appropriate voltage)
4. Multiply line 3 by 4.5 (hours): _____ (This is the maximum kWh possible per day)
5. Multiply line 4 by 365 (days): _____ (This is the maximum kWh possible per year)
6. Divide line 5 by 12 (months): _____ (This is the maximum kWh possible per month)

If line six (6) is equal to or less than line two (2), the system, as designed, will be approved by DEC.

For DEC members that have greater than 12 months of usage history and less than 24 months of usage history, the most recent 12 months of usage history shall be used to obtain the average monthly usage necessary for calculating the inverter size as described above.

For DEC members that have no usage or less than 12 months of usage history, please consult DEC.

8. Generator Disconnect Switch

A lockable disconnect device shall be installed within three (3) feet of the DEC meter and accessible at all times by DEC personnel. The cost of this device and the installation thereof shall not be the responsibility of DEC.

9. Equipment Certification

Equipment that utilizes inverter technology must be compliant with *IEEE 929* and *Underwriters Lab. UL1741*. Equipment that utilizes a rotating machine must be compliant with DEC’s *Technical Requirements for Parallel Operation of Member Owner Generation* document. **By signing below, the Equipment Contractor certifies that the installed generating equipment meets the appropriate preceding requirement(s) and can supply documentation that confirms compliance.**

Company: _____

Name (print): _____ Date: _____

Signature: _____

10. Aggregate Meter Information (if applicable)

The following accounts shall be combined for the purpose of determining the twenty-four (24) months average usage (kWh) as required in the aforementioned formula regarding inverter sizing. Any surplus energy produced by the Generating System will be credited back to the accounts listed below. Each account must be active and ranked according to the order in which credit shall be applied. The specific method of remuneration will be determined by Delaware State Law, the DEC Tariff, and member approval.

1. Name: _____ Rate: _____
Account No.: _____
24 month average usage (kWh): _____ (monthly)
2. Name: _____ Rate: _____
Account No.: _____
24 month average usage (kWh): _____ (monthly)
3. Name: _____ Rate: _____
Account No.: _____
24 month average usage (kWh): _____ (monthly)
4. Name: _____ Rate: _____
Account No.: _____
24 month average usage (kWh): _____ (monthly)
5. Name: _____ Rate: _____
Account No.: _____
4 month average usage (kWh): _____ (monthly)

Any additional meters associated with the aggregated system must be supplied on a separate sheet in the same format.

11. Signatures

DEC Member

I hereby certify that, to the best of my knowledge, all the information provided in this Interconnection Application is true and correct.

Name (print): _____
Date: _____
Signature: _____

Equipment Contractor

I hereby certify that the information regarding the Generating System is complete, accurate, and shall be installed as designed in accordance with all applicable standards.

Name (print): _____
Date: _____
Signature: _____

Electrical Contractor (if different from above)

I hereby certify that all wiring and installation of associated equipment shall be completed in compliance with all applicable NEC codes.

Name (print): _____
Date: _____
Signature: _____

12. PRELIMINARY Approval to Proceed with Interconnection

Returned without review due to insufficient information: _____
Delaware Electric Cooperative: Has Approved ____ Has Not Approved ____ this preliminary application.

Reason for not approving: _____

Name (print): _____

Date: _____

Signature: _____

13. Installation Details

The Generating System will be installed by: Owner: _____

State Licensed Electrician: _____

Installing Electrician: _____

Company: _____ License No.: _____

Mailing Address: _____

Town: _____ State: _____ Zip: _____

Email: _____ Phone: _____

Supply certification that the generating system has been installed and inspected in compliance with the local Building/Electrical code of the municipality of _____.

Signed (Inspector): _____ Date: _____

(In lieu of signature of Inspector, a copy of the final inspection certificate may be attached)

14. FINAL Approval or Non-Approval

Delaware Electric Cooperative: Has Approved ____ Has Not Approved ____ this interconnection application.

Name: _____ Date: _____

Signature: _____

Reason for not approving this Interconnection Application: _____

“Permission to Operate” has been granted as of: _____

ADDENDUM A- INTERCONNECTION AGREEMENT TERMS AND CONDITIONS

1. **Scope of Agreement.** The Interconnection Application (“Application”) and this Addendum (‘collectively the “Agreement”’) establish the conditions pursuant to which Delaware Electric Cooperative (hereinafter “DEC”) and _____ (hereinafter “Member”) agree that the electric generating facilities (the “Facilities”) listed in the Application may be interconnected to DEC’s electric distribution system (“System”).

2. **Establishment of Point of Interconnection.** The point where the electric energy first leaves the wires or facilities owned by DEC and enters the wires or facilities provided by Member is the “Point of Interconnection.” DEC shall determine the Point of Interconnection in accordance with its rules, regulations, by-laws, rates, and Tariffs (the “Rules”), which are incorporated herein by reference. Any interconnection equipment installed by Member (“Interconnection Facilities”) shall also be in accordance with the Rules.

3. **Responsibilities of DEC and Member for Installation, Operation and Maintenance of Facilities.** Member will, at its own cost and expense, install, operate, maintain, repair, and inspect, and shall be fully responsible for, the Facilities listed in the Application and Member’s Interconnection Facilities. Member’s Facilities shall be designed, installed, maintained and operated in a safe and reliable manner, in compliance with all aspects of the Rules, and in accordance with industry standard prudent engineering practice. Maintenance of the Facilities and Interconnection Facilities shall be performed in accordance with the applicable manufacturers’ recommended maintenance schedule.

Member also agrees that the design, installation, maintenance and operation of its Facilities and Interconnection Facilities shall minimize the likelihood of a malfunction or other disturbance, damaging or otherwise affecting or impairing the System. Member shall comply with all applicable laws, regulations, zoning codes, building codes, safety rules and environmental restrictions applicable to the design, installation, operation and maintenance of its Facilities and Interconnection Facilities. Member shall obtain all environmental and other permits lawfully required by governmental authorities prior to the commencement of construction of the Facilities and Interconnection Facilities.

DEC will notify Member if there is evidence that operation of the Facilities or Interconnection Facilities causes, or may cause, disruption or deterioration of service to other members of DEC served by the System, or if operation of the Facilities or Interconnection Facilities causes, or may cause, damage or impairment to the System. Member will notify DEC of any emergency or hazardous condition or occurrence with the Facilities or Interconnection Facilities, which could affect safe operation of the System.

4. **Modifications.** Member will not increase the output of the Facilities or make other material changes or modifications to the configuration or operation of the Facilities or Interconnection Facilities without the prior written consent of DEC. In the event that Member plans to undertake a modification that reasonably may be expected to impact the System, Member shall provide DEC with sufficient information to allow DEC to evaluate the potential impact of the modification prior to commencement of any work.

5. **Net Metering.** All power sales to DEC and net metering shall be governed by DEC’s Tariff and Delaware law, Chapter 10 of Title 26 (Electric Utility Restructuring). Interconnection of the Facilities with the System does not grant Member the right to export power in excess of the applicable limits set forth in DEC’s Tariff of Delaware law, Chapter 10 of Title 26 (Electric Utility Restructuring), nor does it constitute an agreement by DEC to purchase or wheel excess power.

6. **Limitation of Liability and Indemnification.** (a) Member shall be responsible for the safe installation, maintenance, repair and condition of the Facilities and Interconnection Facilities. DEC does not assume any duty of inspecting Member’s lines, wires, switches, or other equipment or property and will not be responsible therefor. Member assumes all liability for and shall indemnify DEC and its members, directors, officers, managers, employees, agents, representatives, affiliates, successors and assigns for and shall hold them harmless from and against any claims, losses, costs, and expenses of any kind or character

that are the result from Member's negligence or other wrongful conduct in connection with the design, construction, installation, operation or maintenance of the Facilities or Interconnection Facilities. Such indemnity shall include, but is not limited to, financial responsibility for (i) monetary losses; (ii) reasonable costs and expenses of defending an action or claim; (iii) damages related to death or injury; (iv) damages to property; and (v) damages for the disruption of business.

DEC's liability to the other party for any loss, cost, claim, injury, liability, or expense, including reasonable attorney's fees, relating to or arising from any act or omission in its performance of this Agreement, shall be limited to the amount of direct damages actually incurred. In no event shall DEC be liable to Member any indirect, incidental, special, consequential, or punitive damages of any kind whatsoever. Member shall indemnify, defend, and save DEC harmless from any and all damages, losses, claims, including claims and actions relating to injury to or death of any person or damage to property, demand, suits, recoveries, costs and expenses, court costs, attorney fees, and all other obligations by or to third parties, arising out of or resulting from the construction, design, installation, operation and maintenance of the Facilities.

7. **Right of Access, Equipment Installation, Removal & Inspection.** DEC may send employees, agents or contractors to Member's premises at any time, whether before, during or after the time the Facilities first produce energy to inspect the Facilities and Interconnection Facilities. DEC may monitor and observe the Facility's installation, commissioning (including any testing), startup, operation, and maintenance. DEC shall at all times have direct, unabated access to the disconnect switch and metering equipment of the Facility. DEC shall provide reasonable notice to Member when possible prior to exercising its right of access.

8. **Disconnection of Facilities.**

(a) DEC may temporarily disconnect the Facilities upon any of the following conditions:

- 1) For scheduled outages upon reasonable notice;
- 2) For unscheduled outages or emergency conditions;
- 3) If the Facilities or Interconnection Facilities do not operate in a manner consistent with the Application or these Terms and Conditions;
- 4) For improper installation or if the Facilities or Interconnection Facilities create a safety, reliability or a power quality problem; or
- 5) The Member's Interconnection Facilities are de-listed by the Nationally Recognized Testing Laboratory that provided the listing at the time the interconnection was approved.

(b) DEC may permanently disconnect or direct Member to disconnect Member's Facility and Interconnection Facilities if this Agreement is terminated.

9. **Governing Law, Regulatory Authority, and Rules.** The validity, interpretation and enforcement of this Agreement and each of its provisions shall be governed by the laws of the State of Delaware. Nothing in this Agreement is intended to affect any other agreement between DEC and Member. However, in the event that a provision of the Agreement conflicts with any provision of DEC's Tariff, the Tariff shall control.

10. **Termination.** This Agreement may be terminated under the following conditions:

(a) By Member: Member may terminate Agreement at any time by providing written notice to DEC;

(b) By DEC: DEC may terminate this Agreement if Member fails to remedy a violation of the terms of this Agreement within 30 calendar days after notice, or such other date as may be mutually agreed to prior to the expiration of the 30 day period.

11. **Severability.** If any portion or provision of this Agreement is held for any reason to be invalid or illegal or unenforceable by any court of competent jurisdiction, such portion shall be deemed to be separate, independent and severable, and the remainder of this Agreement shall remain in full force and effect.

12. **Entirety of Agreement; Amendments.** This Agreement, including the Rules, which are expressly made a part hereof for all purposes, constitutes the entire agreement and understanding between the Parties with regard to the interconnection of the Facilities. No amendments or modifications to this Agreement shall be effective unless in writing and signed by the Parties hereto.

13. **Notices.** Notices given under this Agreement are deemed to have been duly delivered if hand delivered or sent by United States certified mail, return receipt requested, postage prepaid, to Member at the address listed in the Application and to DEC at P.O. Box 600, Sussex Highway, Greenwood, Delaware 19950.

14. **Member Certification.** I hereby certify that: 1) I have read and understand the Terms and Conditions of the Agreement; 2) I have read and understand the Technical Requirements for Member-Owned Generation; 3) I agree to comply with all provisions of the Terms and Conditions; and 4) to the best of my knowledge and belief, all information provided by me in the Application is true and complete.

Member Signature

Printed Name

Date: _____

Appendix E

Generator Interconnection Application
For Projects 500 kW and Greater

Delaware Electric Cooperative, Inc.
Interconnection Application
(For Use with Systems 500 kW AC and Greater)
REVISED May 2019

This Interconnection Application also serves as a binding contract between Delaware Electric Cooperative, Inc. (hereinafter referred to as DEC) and each signatory listed herein.

General Instructions and Expectations

1. The preliminary portion of this application (Sections 1 through 10) Addendum A and Appendix B of this document must be submitted initially along with the application fee or a scanned copy of the check (see Section 5) to:

Delaware Electric Cooperative, Inc.
ATTN: Interconnection Application
PO Box 600
Greenwood, DE 19950

Email: interconnection@delaware.coop

2. Should any Interconnection Application require multiple revisions by the Equipment Contractor and subsequent reviews, DEC reserves the right to charge a fee for each additional review.
3. Any Generating System requiring an upgrade to the DEC utility system will require payment in full for all costs associated with the requested upgrade before construction of the Generating System is permitted to begin.
4. After the preliminary portion of this application (Sections 1 through 10) has been approved by DEC and returned to the Equipment Contractor, construction of the Generating System may begin.
5. The final portion of this application (Sections 1 through 12) and a scanned copy of the Inspection Certificate (if applicable) must be submitted for final approval after construction of the Generating System is complete. Upon submittal, DEC will meet with the Equipment Contractor to perform a field inspection of the installation. Any installations deemed unacceptable to DEC's standards, or any installation that alters the original, approved design intent will be corrected by the Equipment Contractor at no cost to DEC before final approval is granted.
6. When final approval is granted, DEC will install appropriate metering and return the approved Interconnection Application to the Equipment Contractor. Only at that time, will "Permission to Operate" be granted.
7. This application must be filled out in its entirety or it will be returned without review.

Delaware Electric Cooperative, Inc.
Interconnection Application

(For Use with Systems 500 kW AC and Greater)
REVISED May 2019

Type of Application: Initial _____ or Addition/Upgrade _____
Ownership: Leased _____ or Member-Owned _____
Account(s): Single _____ or Aggregated _____

1. DEC Member/ Generator Information

Name: _____

Address: _____

Town: _____ State: _____ Zip: _____

Email: _____ Phone: _____

DEC Account Number: _____

Sq. Ft of Residence: _____ Electric Heat? Yes _____ No _____

2. Equipment Contractor Information

Name: _____

Address: _____

Town: _____ State: _____ Zip: _____

Email: _____ Phone: _____

3. Electrical Contractor Information (If different from above)

Name: _____

Address: _____

Town: _____ State: _____ Zip: _____

Email: _____ Phone: _____

Delaware Electric Cooperative, Inc.
Interconnection Application
(For Use with Systems 500 kW AC and Greater)
REVISED May 2019

4. Facility Information (If different from above)

Address:

Town: _____ State: _____ Zip: _____

Nearest DEC Equipment Tag Number: _____

5. Application Fee

The application fee is \$1000.00 per application for new or upgraded systems 500 kW DC or greater. All Interconnection Applications submitted to DEC shall be accompanied with the appropriate fee made payable to DEC. The application fee is non-refundable. Applications returned for incomplete information will be subject to an additional application fee when resubmitted. No applications will be considered without the application fee. Returned checks will be assessed an additional fee based on DEC's Returned Check Policy.

6. Equipment Information

Is this equipment powered from a renewable source? Yes ____ No ____

Type of energy source:

Solar ____ Wind ____ Diesel ____ Natural Gas ____ Fuel Oil ____ Other ____

Maximum export: _____ kW DC/AC

24 month average usage (kWh) _____ (monthly)

Forecast *monthly* production (kWh) _____

Generator (or solar collector) Manufacturer, Model Name, and Number:

(A copy of the generator nameplate and manufacturer's specification sheet may be substituted)

Quantity of PV Modules: _____ Size of PV Modules: _____

Inverter Manufacturer, Model Name, and Number:

(A copy of the inverter nameplate and manufacturer's specification sheet may be substituted)

Quantity of Inverters: _____

Please fill out the Initial Rating information if there is currently no Generating System on-site. If adding a Generating System to an existing system, fill out the Initial Rating information, the Added Rating information, and the Total Rating information.

Initial Rating:

DC System Design Capacity _____ (kW)
AC System Design Capacity _____ (kW) _____ (kVA)

Added Rating:

DC System Design Capacity _____ (kW)
AC System Design Capacity _____ (kW) _____ (kVA)

Total Rating:

DC System Design Capacity _____ (kW)
AC System Design Capacity _____ (kW) _____ (kVA)

7. Generator Disconnect Switch

A lockable disconnect device shall be installed within three (3) feet of the DEC meter and accessible at all times by DEC personnel. The cost of this device and the installation thereof shall not be the responsibility of DEC.

8. Equipment Certification

Equipment that utilizes inverter technology must be compliant with *IEEE 929* and *Underwriters Lab. UL1741*. Equipment that utilizes a rotating machine must be compliant with DEC’s *Technical Requirements for Parallel Operation of Member Owner Generation* document. **By signing below, the Equipment Contractor certifies that the installed generating equipment meets the appropriate preceding requirement(s) and can supply documentation that confirms compliance.**

Company: _____

Name (print): _____ Date: _____

Signature: _____

9. Signatures

Generator Owner

I hereby certify that, to the best of my knowledge, all the information provided in this Interconnection Application is true and correct.

Name (print): _____

Date: _____

Signature: _____

Equipment Contractor

I hereby certify that the information regarding the Generating System is complete, accurate, and shall be installed as designed in accordance with all applicable standards.

Name (print): _____

Date: _____

Signature: _____

Electrical Contractor (if different from above)

I hereby certify that all wiring and installation of associated equipment shall be completed in compliance with all applicable *NEC* codes.

Name (print): _____

Date: _____

Signature: _____

10. PRELIMINARY Approval to Proceed with Interconnection

Returned without review due to insufficient information: _____

Delaware Electric Cooperative: Has Approved ____ Has Not Approved ____ this preliminary application.

Reason for not approving: _____

Name (print): _____

Date: _____

Signature: _____

11. Installation Details

The Generating System will be installed by: Owner: _____

State Licensed Electrician: _____

Installing Electrician: _____

Company: _____ License No.: _____

Mailing Address: _____

Town: _____ State: _____ Zip: _____

Email: _____ Phone: _____

Supply certification that the generating system has been installed and inspected in compliance with the local Building/Electrical code of the municipality of _____.

Signed (Inspector): _____

Date: _____

(In lieu of signature of Inspector, a copy of the final inspection certificate may be attached)

12. FINAL Approval or Non-Approval

Delaware Electric Cooperative: Has Approved ____ Has Not Approved ____ this interconnection application.

Name: _____

Date: _____

Signature: _____

Reason for not approving this Interconnection Application: _____

“Permission to Operate” has been granted as of: _____

ADDENDUM B- INTERCONNECTION AGREEMENT TERMS AND CONDITIONS

1. Scope of Agreement. The Interconnection Application (“Application”) and this Addendum (“collectively the “Agreement”) establish the conditions pursuant to which Delaware Electric Cooperative (hereinafter “DEC”) and _____ (hereinafter “Generator”) agree that the electric generating facilities (the “Facilities”) listed in the Application may be interconnected to DEC’s electric distribution system (“System”).

2. Establishment of Point of Interconnection. The point where the electric energy first leaves the wires or facilities owned by DEC and enters the wires or facilities provided by Generator is the “Point of Interconnection.” DEC shall determine the Point of Interconnection in accordance with its rules, regulations, by-laws, rates, and Tariffs (the “Rules”), which are incorporated herein by reference. Any interconnection equipment installed by Generator (“Interconnection Facilities”) shall also be in accordance with the Rules.

3. Responsibilities of DEC and Generator for Installation, Operation and Maintenance of Facilities. Generator will, at its own cost and expense, install, operate, maintain, repair, and inspect, and shall be fully responsible for, the Facilities listed in the Application and Generator’s Interconnection Facilities. Generator’s Facilities shall be designed, installed, maintained and operated in a safe and reliable manner, in compliance with all aspects of the Rules, and in accordance with industry standard prudent engineering practice. Maintenance of the Facilities and Interconnection Facilities shall be performed in accordance with the applicable manufacturers’ recommended maintenance schedule.

Generator also agrees that the design, installation, maintenance and operation of its Facilities and Interconnection Facilities shall minimize the likelihood of a malfunction or other disturbance, damaging or otherwise affecting or impairing the System. Generator shall comply with all applicable laws, regulations, zoning codes, building codes, safety rules and environmental restrictions applicable to the design, installation, operation and maintenance of its Facilities and Interconnection Facilities. Generator shall obtain all environmental and other permits lawfully required by governmental authorities prior to the commencement of construction of the Facilities and Interconnection Facilities.

DEC will notify Generator if there is evidence that operation of the Facilities or Interconnection Facilities causes, or may cause, disruption or deterioration of service to other members of DEC served by the System, or if operation of the Facilities or Interconnection Facilities causes, or may cause, damage or impairment to the System. Generator will notify DEC of any emergency or hazardous condition or occurrence with the Facilities or Interconnection Facilities, which could affect safe operation of the System.

4. Modifications. Generator will not increase the output of the Facilities or make other material changes or modifications to the configuration or operation of the Facilities or Interconnection Facilities without the prior written consent of DEC. In the event that Generator plans to undertake a modification that reasonably may be expected to impact the System, Generator shall provide DEC with sufficient information to allow DEC to evaluate the potential impact of the modification prior to commencement of any work.

5. Metering. A power sales to DEC metering shall be governed by DEC’s and Generator’s Purchase Power Agreement dated _____.

6. Export Power. Exported power to others utilizing DEC’s system will be subject to all tariffs, costs and fees of DEC.

7. Limitation of Liability and Indemnification. (a) Generator shall be responsible for the safe installation, maintenance, repair and condition of the Facilities and Interconnection Facilities. DEC does not assume any duty of inspecting Generator’s lines, wires, switches, or other equipment or property and will not be responsible therefor. Generator assumes all liability for and shall indemnify DEC and its members, directors, officers, managers, employees, agents, representatives, affiliates, successors and assigns for and shall hold them harmless from and against any claims, losses, costs, and expenses of any kind or character

that are the result from Generator's negligence or other wrongful conduct in connection with the design, construction, installation, operation or maintenance of the Facilities or Interconnection Facilities. Such indemnity shall include, but is not limited to, financial responsibility for (i) monetary losses; (ii) reasonable costs and expenses of defending an action or claim; (iii) damages related to death or injury; (iv) damages to property; and (v) damages for the disruption of business.

DEC's liability to the other party for any loss, cost, claim, injury, liability, or expense, including reasonable attorney's fees, relating to or arising from any act or omission in its performance of this Agreement, shall be limited to the amount of direct damages actually incurred. In no event shall DEC be liable to Generator any indirect, incidental, special, consequential, or punitive damages of any kind whatsoever. Member shall indemnify, defend, and save DEC harmless from any and all damages, losses, claims, including claims and actions relating to injury to or death of any person or damage to property, demand, suits, recoveries, costs and expenses, court costs, attorney fees, and all other obligations by or to third parties, arising out of or resulting from the construction, design, installation, operation and maintenance of the Facilities.

8. Right of Access, Equipment Installation, Removal & Inspection. DEC may send employees, agents or contractors to Generator's premises at any time, whether before, during or after the time the Facilities first produce energy to inspect the Facilities and Interconnection Facilities. DEC may monitor and observe the Facility's installation, commissioning (including any testing), startup, operation, and maintenance. DEC shall at all times have direct, unabated access to the disconnect switch and metering equipment of the Facility. DEC shall provide reasonable notice to Generator when possible prior to exercising its right of access.

9. Disconnection of Facilities.

(a) DEC may temporarily disconnect the Facilities upon any of the following conditions:

- 1) For scheduled outages upon reasonable notice;
- 2) For unscheduled outages or emergency conditions;
- 3) If the Facilities or Interconnection Facilities do not operate in a manner consistent with the Application or these Terms and Conditions;
- 4) For improper installation or if the Facilities or Interconnection Facilities create a safety, reliability or a power quality problem; or
- 5) The Generator's Interconnection Facilities are de-listed by the Nationally Recognized Testing Laboratory that provided the listing at the time the interconnection was approved.

(b) DEC may permanently disconnect or direct Generator to disconnect Generator's Facility and Interconnection Facilities if this Agreement is terminated.

10. Governing Law, Regulatory Authority, and Rules. The validity, interpretation and enforcement of this Agreement and each of its provisions shall be governed by the laws of the State of Delaware. Nothing in this Agreement is intended to affect any other agreement between DEC and Generator. However, in the event that a provision of the Agreement conflicts with any provision of DEC's Tariff, the Tariff shall control.

11. Termination. This Agreement may be terminated under the following conditions:

- (a) By Generator: Generator may terminate Agreement at any time by providing written notice to DEC;
- (b) By DEC: DEC may terminate this Agreement if Generator fails to remedy a violation of the terms of this Agreement within 30 calendar days after notice, or such other date as may be mutually agreed to prior to the expiration of the 30 day period.
- (c) Termination of this Agreement will not be in violation of any Purchase Power Agreements between DEC and Generator

12. Severability. If any portion or provision of this Agreement is held for any reason to be invalid or illegal or unenforceable by any court of competent jurisdiction, such portion shall be deemed to be separate, independent and severable, and the remainder of this Agreement shall remain in full force and effect.

13. Entirety of Agreement; Amendments. This Agreement, including the Rules, which are expressly made a part hereof for all purposes, constitutes the entire agreement and understanding between the Parties with regard to the interconnection of the Facilities. No amendments or modifications to this Agreement shall be effective unless in writing and signed by the Parties hereto.

14. Notices. Notices given under this Agreement are deemed to have been duly delivered if hand delivered or sent by United States certified mail, return receipt requested, postage prepaid, to Generator at the address listed in the Application and to DEC at P.O. Box 600, Sussex Highway, Greenwood, Delaware 19950.

15. Generator Certification. I hereby certify that: 1) I have read and understand the Terms and Conditions of the Agreement; 2) I have read and understand the Technical Requirements for Generator-Owned Generation; 3) I agree to comply with all provisions of the Terms and Conditions; and 4) to the best of my knowledge and belief, all information provided by me in the Application is true and complete.

Member Signature

Printed Name

Date

Appendix F

Typical Basic One-Line Diagrams

V:\Clients\Tennessee\EC\Generation\Solar Farm\Interconnection One Line Diagram\DC Gen Indicated Dist Circuit Fig 1.dwg

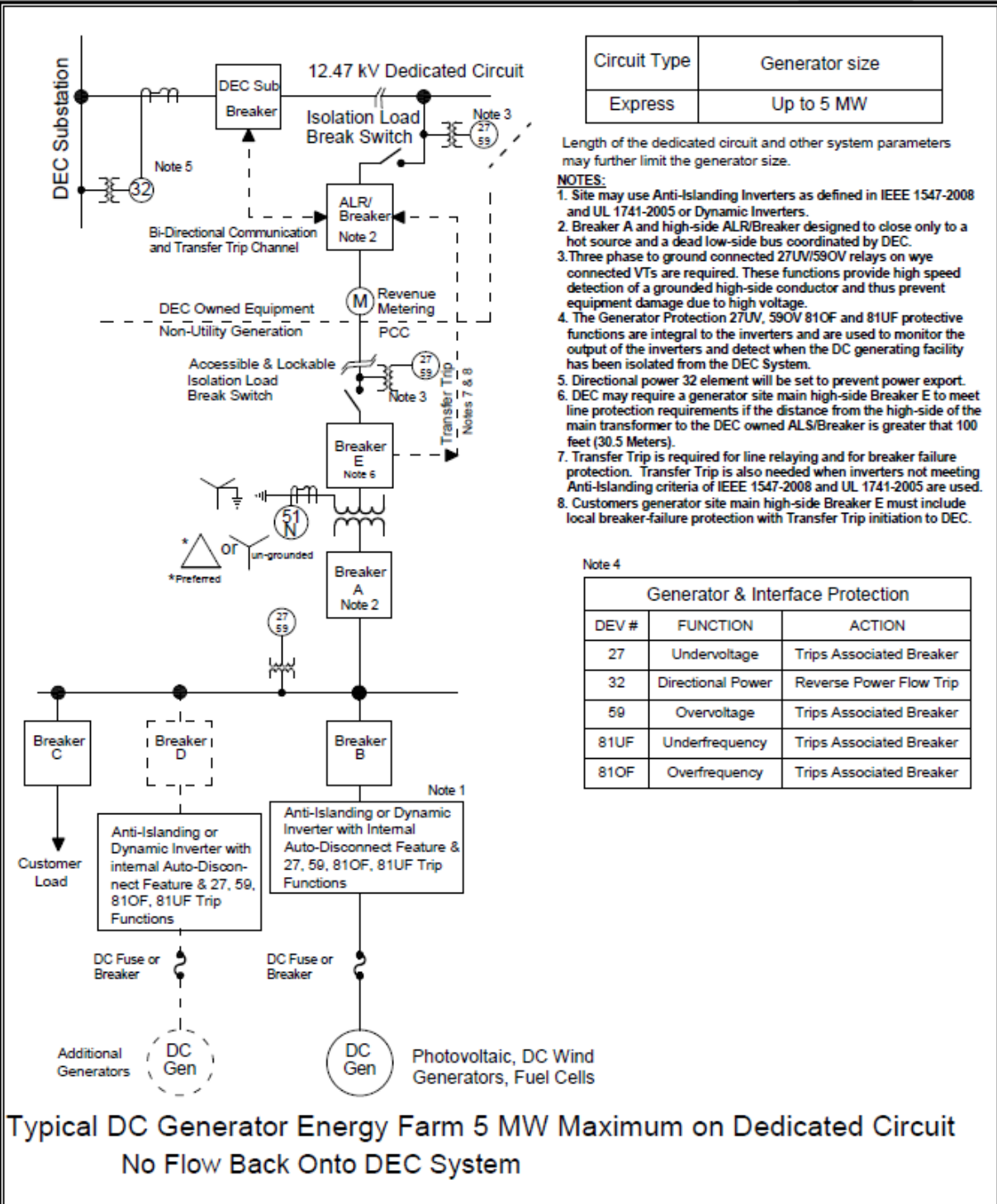

Circuit Type	Generator size
Express	Up to 5 MW

Length of the dedicated circuit and other system parameters may further limit the generator size.

- NOTES:**
1. Site may use Anti-Islanding Inverters as defined in IEEE 1547-2008 and UL 1741-2005 or Dynamic Inverters.
 2. Breaker A and high-side ALR/Breaker designed to close only to a hot source and a dead low-side bus coordinated by DEC.
 3. Three phase to ground connected 27UV/59OV relays on wye connected VTs are required. These functions provide high speed detection of a grounded high-side conductor and thus prevent equipment damage due to high voltage.
 4. The Generator Protection 27UV, 59OV 81OF and 81UF protective functions are integral to the inverters and are used to monitor the output of the inverters and detect when the DC generating facility has been isolated from the DEC System.
 5. Directional power 32 element will be set to prevent power export.
 6. DEC may require a generator site main high-side Breaker E to meet line protection requirements if the distance from the high-side of the main transformer to the DEC owned ALS/Breaker is greater than 100 feet (30.5 Meters).
 7. Transfer Trip is required for line relaying and for breaker failure protection. Transfer Trip is also needed when inverters not meeting Anti-Islanding criteria of IEEE 1547-2008 and UL 1741-2005 are used.
 8. Customers generator site main high-side Breaker E must include local breaker-failure protection with Transfer Trip initiation to DEC.

Note 4

Generator & Interface Protection		
DEV #	FUNCTION	ACTION
27	Undervoltage	Trips Associated Breaker
32	Directional Power	Reverse Power Flow Trip
59	Overtvoltage	Trips Associated Breaker
81UF	Underfrequency	Trips Associated Breaker
81OF	Overfrequency	Trips Associated Breaker

**Typical DC Generator Energy Farm 5 MW Maximum on Dedicated Circuit
No Flow Back Onto DEC System**

DELAWARE ELECTRIC CO-OP GREENWOOD DELAWARE 19950	CLIENT PROJ.	REV	DATE	DESCRIPTION		DWG. NO. FIGURE 1
	POWER SERVICES PROJ. NO. 11-323-17420001	A	01/12/12	To Client for comments		
FIGURE 1 ONE WAY POWER FLOW	DATE: JAN 11, 2012	a	01/18/12	Gnd WYE Low Voltage	1616 E. Millbrook Rd. Suite 210 Raleigh, NC 27609 TEL: 919-256-5900 FAX: 919-256-5939	FIGURE 1
DC GENERATOR ENERGY FARM CONNECTION TO DISTRIBUTION	SCALE: AS SHOWN					
	DWN BY: HWH CKD BY: GLB APPVD BY: GLB 01/12/12					

V:\Clients\Delaware EC\Generation\Solar Farm\Interconnection One Line Diagram Gen 2 Way Dist Circuit Fig 2.dwg

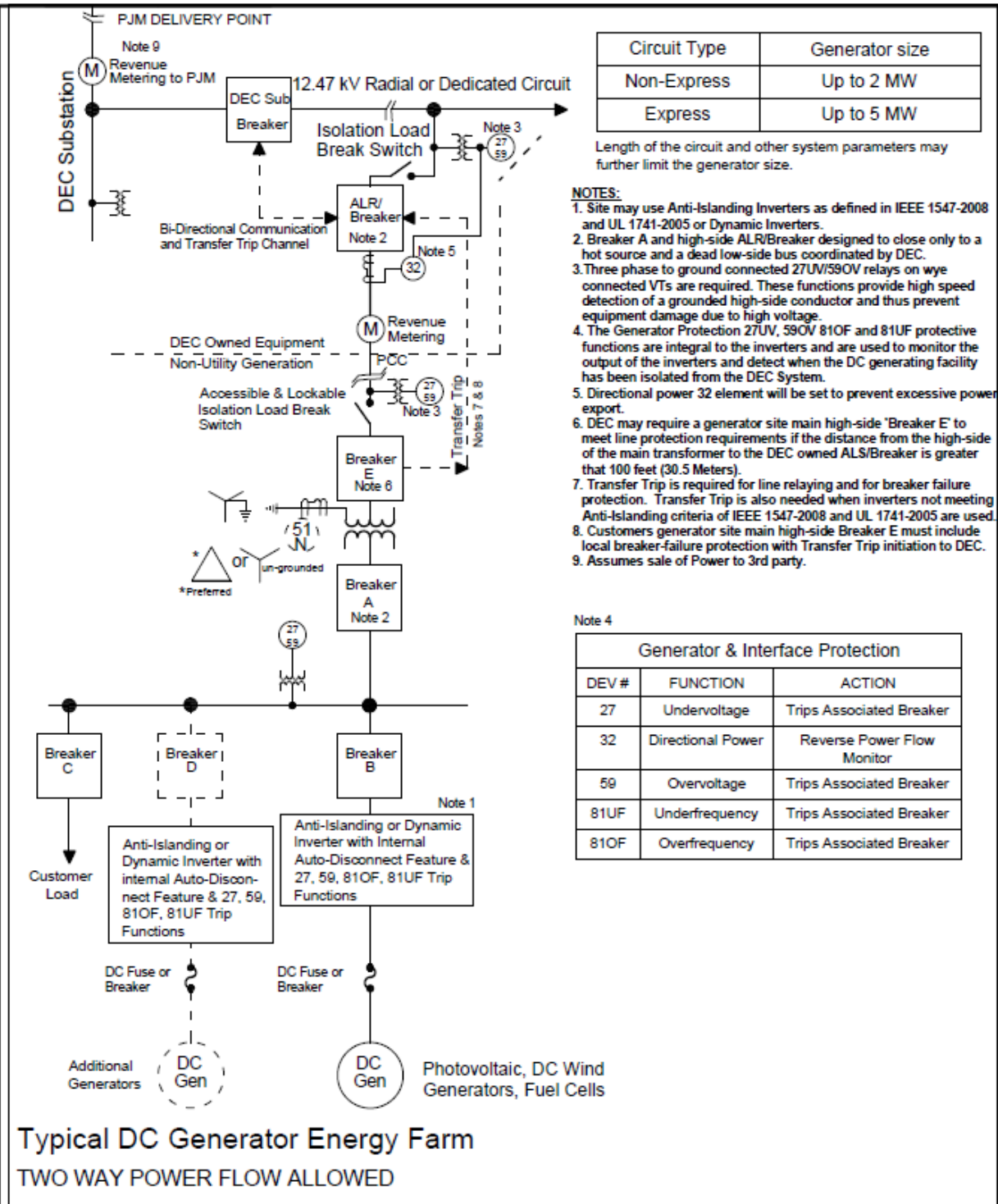

Circuit Type	Generator size
Non-Express	Up to 2 MW
Express	Up to 5 MW

Length of the circuit and other system parameters may further limit the generator size.

- NOTES:**
1. Site may use Anti-Islanding Inverters as defined in IEEE 1547-2008 and UL 1741-2005 or Dynamic Inverters.
 2. Breaker A and high-side ALR/Breaker designed to close only to a hot source and a dead low-side bus coordinated by DEC.
 3. Three phase to ground connected 27UV/59OV relays on wye connected VTs are required. These functions provide high speed detection of a grounded high-side conductor and thus prevent equipment damage due to high voltage.
 4. The Generator Protection 27UV, 59OV 81OF and 81UF protective functions are integral to the inverters and are used to monitor the output of the inverters and detect when the DC generating facility has been isolated from the DEC System.
 5. Directional power 32 element will be set to prevent excessive power export.
 6. DEC may require a generator site main high-side 'Breaker E' to meet line protection requirements if the distance from the high-side of the main transformer to the DEC owned ALS/Breaker is greater than 100 feet (30.5 Meters).
 7. Transfer Trip is required for line relaying and for breaker failure protection. Transfer Trip is also needed when inverters not meeting Anti-Islanding criteria of IEEE 1547-2008 and UL 1741-2005 are used.
 8. Customers generator site main high-side Breaker E must include local breaker-failure protection with Transfer Trip initiation to DEC.
 9. Assumes sale of Power to 3rd party.

Note 4

Generator & Interface Protection		
DEV #	FUNCTION	ACTION
27	Undervoltage	Trips Associated Breaker
32	Directional Power	Reverse Power Flow Monitor
59	Overvoltage	Trips Associated Breaker
81UF	Underfrequency	Trips Associated Breaker
81OF	Overfrequency	Trips Associated Breaker

DELAWARE ELECTRIC CO-OP GREENWOOD DELAWARE 19950	CLIENT PROJ. REF. NO.: POWER SERVICES PROJ. NO. 11-323-1742-0001	REV. DATE DESCRIPTION A 01/17/12 FOR REVIEW	<p>1616 E. Millbrook Rd. Suite 210 Raleigh, NC 27609 TEL: 919-256-5900 FAX: 919-256-5939</p>	DWG. NO. FIGURE 2
FIGURE 2 TWO WAY POWER FLOW				
DC GENERATOR ENERGY FARM CONNECTION TO DISTRIBUTION				
SCALE: AS SHOWN DWN BY: H/H CKD BY: GLB APPVD BY:				

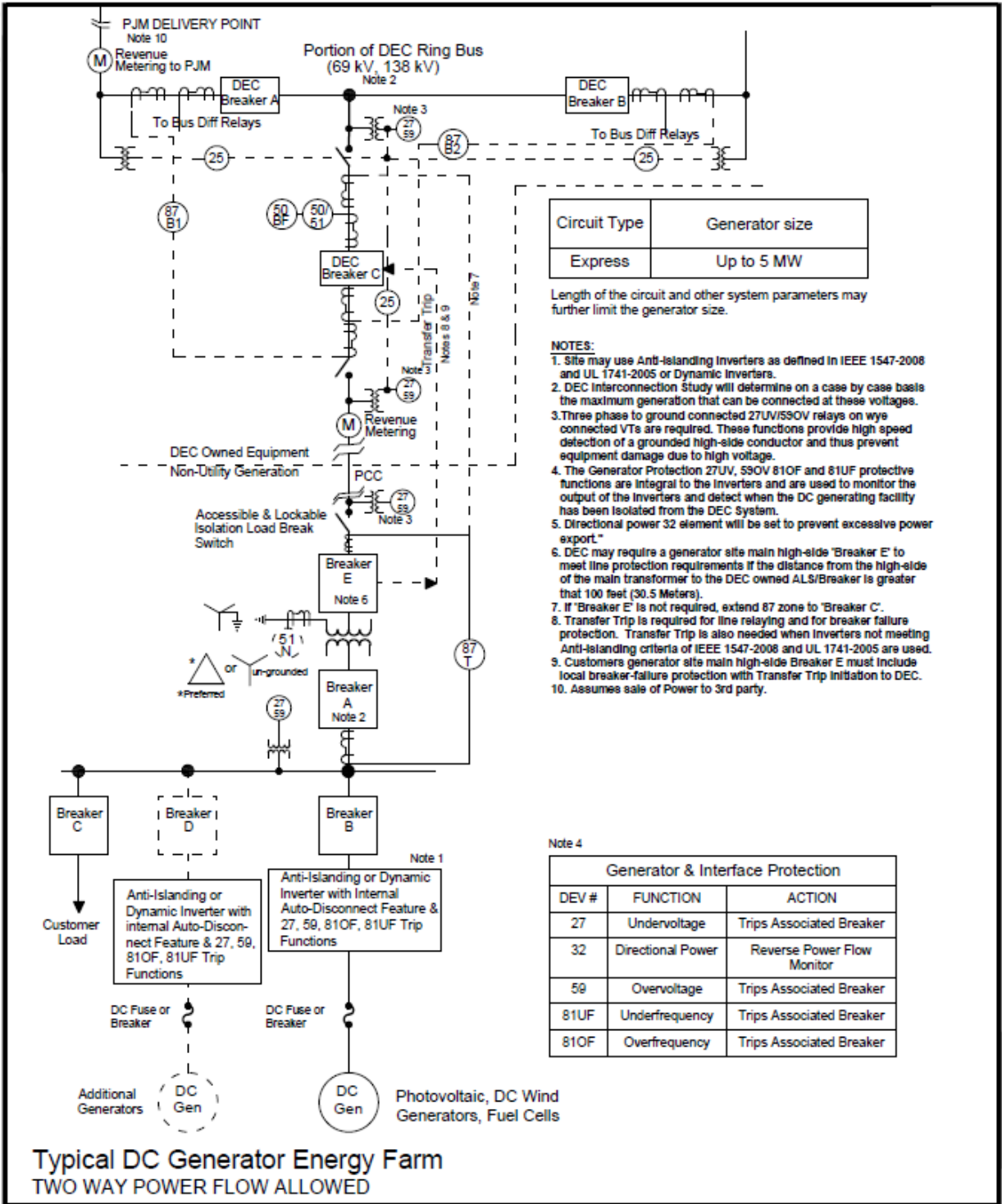

Circuit Type	Generator size
Express	Up to 5 MW

Length of the circuit and other system parameters may further limit the generator size.

- NOTES:**
1. Site may use Anti-islanding Inverters as defined in IEEE 1547-2008 and UL 1741-2005 or Dynamic Inverters.
 2. DEC Interconnection Study will determine on a case by case basis the maximum generation that can be connected at these voltages.
 3. Three phase to ground connected 27UV/SSOV relays on wye connected VTs are required. These functions provide high speed detection of a grounded high-side conductor and thus prevent equipment damage due to high voltage.
 4. The Generator Protection 27UV, SSOV 81OF and 81UF protective functions are integral to the inverters and are used to monitor the output of the inverters and detect when the DC generating facility has been isolated from the DEC system.
 5. Directional power 32 element will be set to prevent excessive power export.
 6. DEC may require a generator site main high-side 'Breaker E' to meet line protection requirements if the distance from the high-side of the main transformer to the DEC owned ALS/Breaker is greater than 100 feet (30.5 Meters).
 7. If 'Breaker E' is not required, extend 87 zone to 'Breaker C'.
 8. Transfer Trip is required for line rlaying and for breaker failure protection. Transfer Trip is also needed when inverters not meeting Anti-islanding criteria of IEEE 1547-2008 and UL 1741-2005 are used.
 9. Customers generator site main high-side Breaker E must include local breaker-failure protection with Transfer Trip Initiation to DEC.
 10. Assumes sale of Power to 3rd party.

Note 4

Generator & Interface Protection		
DEV #	FUNCTION	ACTION
27	Undervoltage	Trips Associated Breaker
32	Directional Power	Reverse Power Flow Monitor
59	Overvoltage	Trips Associated Breaker
81UF	Underfrequency	Trips Associated Breaker
81OF	Overfrequency	Trips Associated Breaker

DELAWARE ELECTRIC CO-OP GREENWOOD DELAWARE 19950	CLIENT PROJ. REF. NO.: POWER SERVICES PROJ. NO.: 11-323-1742-0001 DATE: JAN 11, 2012 SCALE: AS SHOWN DWN BY: HVM CKD BY: GLB APPVD BY:	REV. DATE DESCRIPTION A 01/17/12 FOR REVIEW	DWG. NO. FIGURE 3 FIGURE 3 1616 E. Millbrook Rd, Suite 210 Raleigh, NC 27609 TEL: 919-256-5900 FAX: 919-256-5939
---	--	--	---

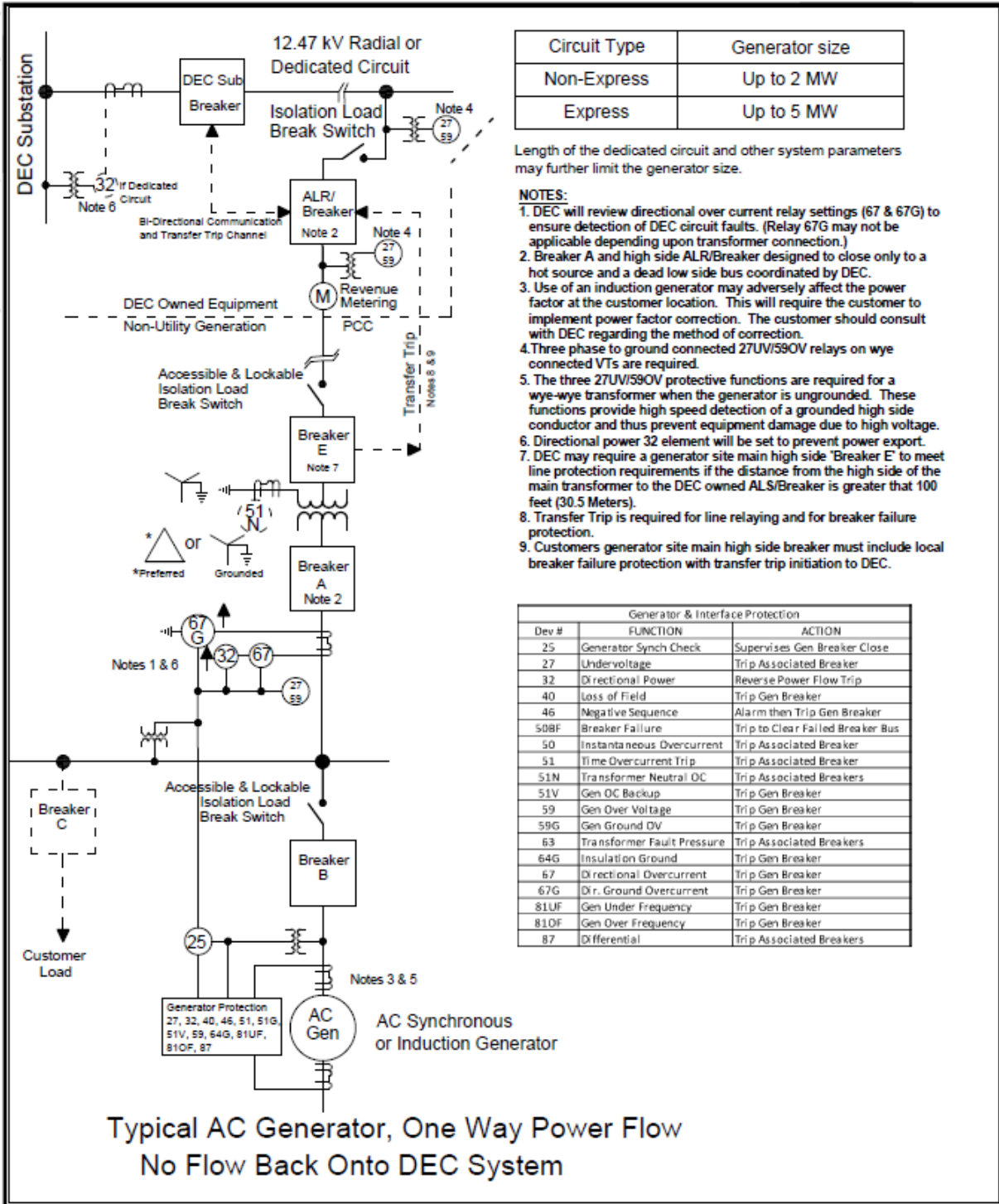

Circuit Type	Generator size
Non-Express	Up to 2 MW
Express	Up to 5 MW

Length of the dedicated circuit and other system parameters may further limit the generator size.

- NOTES:**
- DEC will review directional over current relay settings (67 & 67G) to ensure detection of DEC circuit faults. (Relay 67G may not be applicable depending upon transformer connection.)
 - Breaker A and high side ALR/Breaker designed to close only to a hot source and a dead low side bus coordinated by DEC.
 - Use of an induction generator may adversely affect the power factor at the customer location. This will require the customer to implement power factor correction. The customer should consult with DEC regarding the method of correction.
 - Three phase to ground connected 27UV/59OV relays on wye connected VTs are required.
 - The three 27UV/59OV protective functions are required for a wye-wye transformer when the generator is ungrounded. These functions provide high speed detection of a grounded high side conductor and thus prevent equipment damage due to high voltage.
 - Directional power 32 element will be set to prevent power export.
 - DEC may require a generator site main high side 'Breaker E' to meet line protection requirements if the distance from the high side of the main transformer to the DEC owned ALS/Breaker is greater than 100 feet (30.5 Meters).
 - Transfer Trip is required for line relaying and for breaker failure protection.
 - Customers generator site main high side breaker must include local breaker failure protection with transfer trip initiation to DEC.

Generator & Interface Protection		
Dev #	FUNCTION	ACTION
25	Generator Synch Check	Supervises Gen Breaker Close
27	Undervoltage	Trip Associated Breaker
32	Directional Power	Reverse Power Flow Trip
40	Loss of Field	Trip Gen Breaker
46	Negative Sequence	Alarm then Trip Gen Breaker
50BF	Breaker Failure	Trip to Clear Failed Breaker Bus
50	Instantaneous Overcurrent	Trip Associated Breaker
51	Time Overcurrent Trip	Trip Associated Breaker
51N	Transformer Neutral DC	Trip Associated Breakers
51V	Gen OC Backup	Trip Gen Breaker
59	Gen Over Voltage	Trip Gen Breaker
59G	Gen Ground DV	Trip Gen Breaker
63	Transformer Fault Pressure	Trip Associated Breakers
64G	Insulation Ground	Trip Gen Breaker
67	Directional Overcurrent	Trip Gen Breaker
67G	Dir. Ground Overcurrent	Trip Gen Breaker
81UF	Gen Under Frequency	Trip Gen Breaker
81OF	Gen Over Frequency	Trip Gen Breaker
87	Differential	Trip Associated Breakers

DELAWARE ELECTRIC CO-OP GREENWOOD DELAWARE 19950	CLIENT PROJ. REF. NO.: POWER SERVICES PROJ. NO.: 11-323-1742-0001 DATE: JAN 11, 2012 SCALE: AS SHOWN DWN BY: HVH CKD BY: GLB APPVD BY: GLB 01/12/12	REV. DATE DESCRIPTION A 01/12/12 To Client for comments B 01/18/12 Gnd WYE Low Voltage	DWG. NO. FIGURE 4
FIGURE 4 ONE WAY POWER FLOW			
AC GENERATOR ENERGY FARM CONNECTION TO DISTRIBUTION		1616 E. Millbrook Rd. Suite 210 Raleigh, NC 27609 TEL: 919-256-5900 FAX: 919-256-5939	

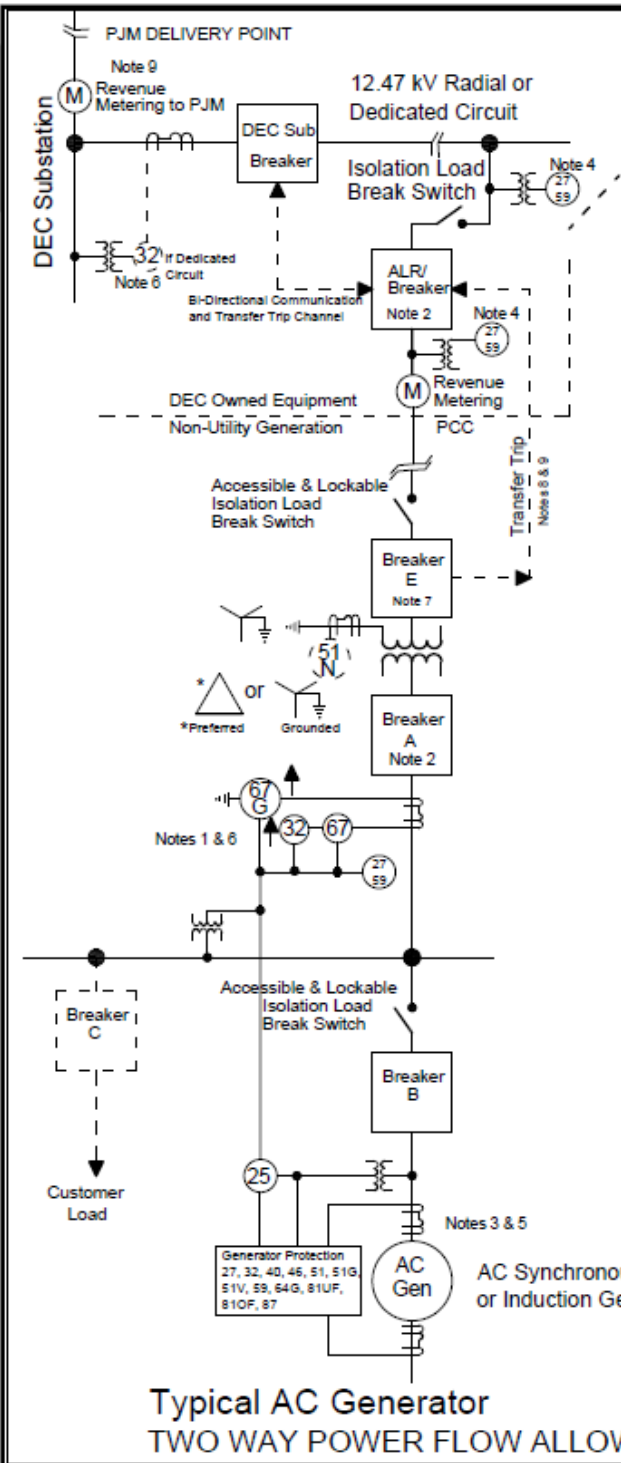



Circuit Type	Generator size
Non-Express	Up to 2 MW
Express	Up to 5 MW

Length of the dedicated circuit and other system parameters may further limit the generator size.

- NOTES:**
- DEC will review directional over current relay settings (67 & 67G) to ensure detection of DEC circuit faults. (Relay 67G may not be applicable depending upon transformer connection.)
 - Breaker A and high-side ALR/Breaker designed to close only to a hot source and a dead low-side bus coordinated by DEC.
 - Use of an induction generator may adversely affect the power factor at the customer location. This will require the customer to implement power factor correction. The customer should consult with DEC regarding the method of correction.
 - Three phase to ground connected 27UV/59OV relays on wye connected VTs are required.
 - The three 27UV/59OV protective functions are required for a wye-wye transformer when the generator is ungrounded. These functions provide high speed detection of a grounded high-side conductor and thus prevent equipment damage due to high voltage.
 - Directional power 32 element will be set to prevent excessive power export.
 - DEC may require a generator site main high-side "Breaker E" to meet line protection requirements if the distance from the high-side of the main transformer to the DEC owned ALS/Breaker is greater than 100 feet (30.5 Meters).
 - Transfer Trip is required for line relaying and for breaker failure protection.
 - Customers generator site main high-side breaker must include local breaker failure protection with Transfer Trip initiation to DEC.

Generator & Interface Protection		
Dev #	FUNCTION	ACTION
25	Generator Synch Check	Supervises Gen Breaker Close
27	Undervoltage	Trip Associated Breaker
32	Directional Power	Reverse Power Flow Monitor
40	Loss of Field	Trip Gen Breaker
46	Negative Sequence	Alarm then Trip Gen Breaker
50BF	Breaker Failure	Trip to Clear Failed Breaker Bus
50	Instantaneous Overcurrent	Trip Associated Breaker
51	Time Overcurrent Trip	Trip Associated Breaker
51N	Transformer Neutral DC	Trip Associated Breakers
51V	Gen OC Backup	Trip Gen Breaker
59	Gen Over Voltage	Trip Gen Breaker
59G	Gen Ground OV	Trip Gen Breaker
63	Transformer Fault Pressure	Trip Associated Breakers
64G	Insulation Ground	Trip Gen Breaker
67	Directional Overcurrent	Trip Gen Breaker
67G	Dir. Ground Overcurrent	Trip Gen Breaker
81UF	Gen Under Frequency	Trip Gen Breaker
81OF	Gen Over Frequency	Trip Gen Breaker
87	Differential	Trip Associated Breakers

**Typical AC Generator
TWO WAY POWER FLOW ALLOWED**

DELAWARE ELECTRIC CO-OP GREENWOOD DELAWARE 19950	CLIENT PROJ. REF. NO.:	REV. DATE DESCRIPTION		DWG. NO.
	POWER SERVICES PROJ. NO. 11-323-17420001	A 01/12/12 To Client for comments		
FIGURE 5 TWO WAY POWER FLOW	DATE: JAN 11, 2012	B 01/16/12 Gnd WYE Low Voltage		FIGURE 5
	SCALE: AS SHOWN			
AC GENERATOR ENERGY FARM CONNECTION TO DISTRIBUTION	DWN BY: HVH		1616 E. Millbrook Rd. Suite 210 Raleigh, NC 27609 TEL: 919-256-5900 FAX: 919-256-5939	
	CKD BY: GLB			
	APPVD BY: GLB 01/12/12			

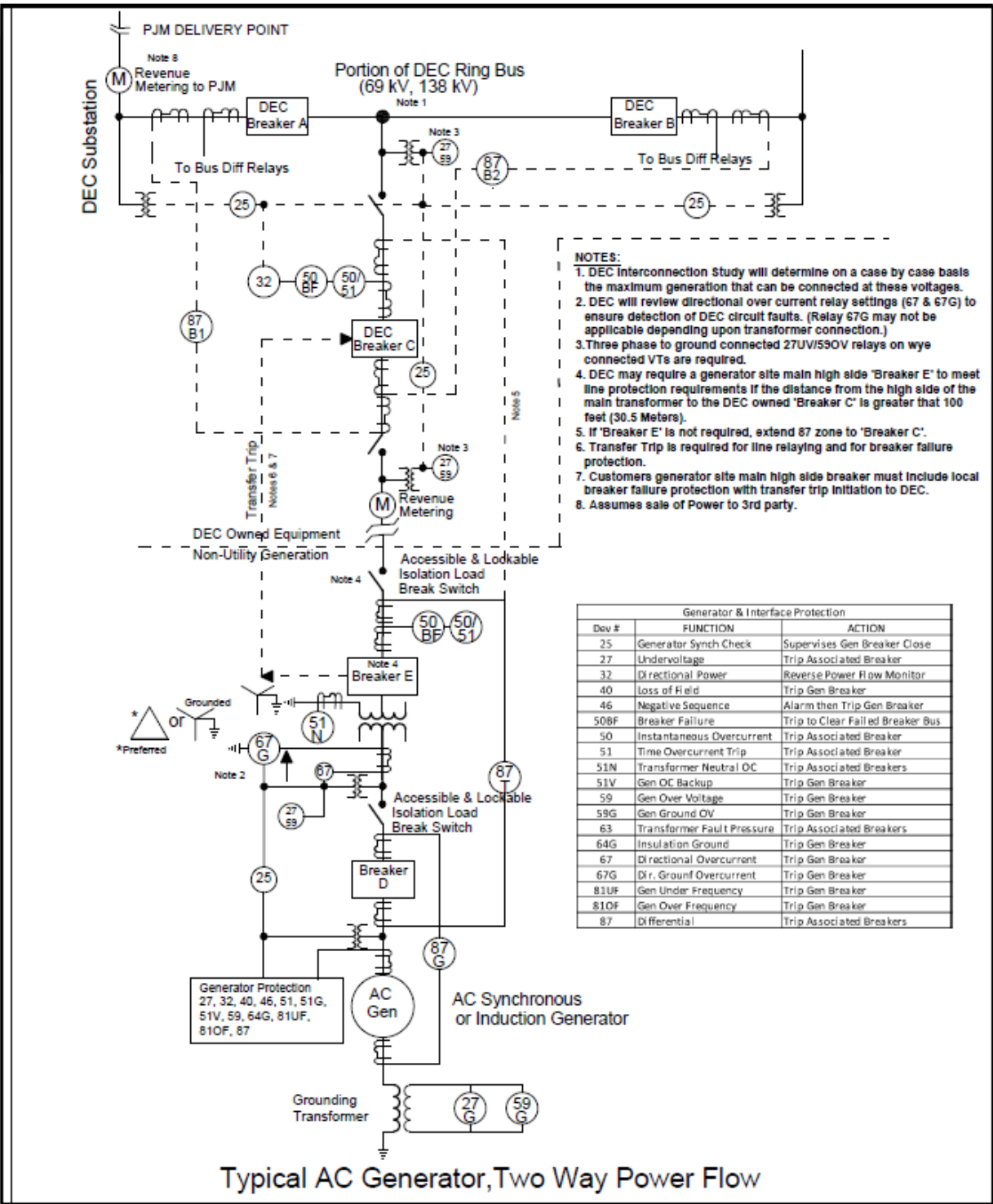

- NOTES:**
1. DEC Interconnection Study will determine on a case by case basis the maximum generation that can be connected at these voltages.
 2. DEC will review directional over current relay settings (67 & 67G) to ensure detection of DEC circuit faults. (Relay 67G may not be applicable depending upon transformer connection.)
 3. Three phase to ground connected 27UV/59OV relays on wye connected VTs are required.
 4. DEC may require a generator site main high side "Breaker E" to meet line protection requirements if the distance from the high side of the main transformer to the DEC owned "Breaker C" is greater than 100 feet (30.5 Meters).
 5. If "Breaker E" is not required, extend 87 zone to "Breaker C".
 6. Transfer Trip is required for line relaying and for breaker failure protection.
 7. Customers generator site main high side breaker must include local breaker failure protection with transfer trip initiation to DEC.
 8. Assumes sale of Power to 3rd party.

Generator & Interface Protection		
Dev #	FUNCTION	ACTION
25	Generator Synch Check	Supervises Gen Breaker Close
27	Undervoltage	Trip Associated Breaker
32	Directional Power	Reverse Power Flow Monitor
40	Loss of Field	Trip Gen Breaker
46	Negative Sequence	Alarm then Trip Gen Breaker
50BF	Breaker Failure	Trip to Clear Failed Breaker Bus
50	Instantaneous Overcurrent	Trip Associated Breaker
51	Time Overcurrent Trip	Trip Associated Breaker
51N	Transformer Neutral DC	Trip Associated Breakers
51V	Gen OC Backup	Trip Gen Breaker
59	Gen Over Voltage	Trip Gen Breaker
59G	Gen Ground OV	Trip Gen Breaker
63	Transformer Fault Pressure	Trip Associated Breakers
64G	Insulation Ground	Trip Gen Breaker
67	Directional Overcurrent	Trip Gen Breaker
67G	Dir. Ground Overcurrent	Trip Gen Breaker
81UF	Gen Under Frequency	Trip Gen Breaker
81OF	Gen Over Frequency	Trip Gen Breaker
87	Differential	Trip Associated Breakers

DELAWARE ELECTRIC CO-OP GREENWOOD DELAWARE 19950	CLIENT PROJ. REF. NO. POWER SERVICES PROJ. NO. 11-323-1742-0001	REV. DATE DESCRIPTION A 01/12/12 To Client for comments B 01/18/12 Gnd WYE Low Voltage	DWG. NO. FIGURE 6
FIGURE 6 TWO WAY POWER FLOW		1616 E. Millbrook Rd, Suite 210 Raleigh, NC 27609 TEL: 919-256-5900 FAX: 919-256-5939	
AC GENERATOR ENERGY FARM CONNECTION TO TRANSMISSION		FIGURE 6	